

Banquet Trolleys 2 Kw GBA100H



Short From Specification

Name: _____

Item: _____

Model: _____

General Features

- The convection-heated banquet trolleys can be used dry or with moist air, depending on what is best for your food.
- Digital control with cabinet temperature display and setting. Fully compliant HACCP digital controls include visible alarms.
- Large storage area suitable to contain 2/1 GN containers or shelves on anti-tilt pressed runners.
- Optimized bottom to up forced air flow provide even temperature distribution and fast heating in any conditions.
- Cabinet fitted with up to 40 mm thickness of polyurethane insulation for best insulating performance with 100% environmental protection.
- Removable triple-chamber balloon magnetic gasket to improve insulation consumption.
- Spacers on the sides-end ensure that the convection air in the interior of the banquet trolley can circulate all around, achieving temperature distribution which is as even as possible.
- The slide-in convection-heated module can be removed particularly easily.
- The water tank for the moist-air heating can also be removed conveniently.
- Gn can be manually filled with water.
- The heat can be monitored and adjusted between 50-80 °C with the thermometer.
- Dashpot dampers project the unit against damages.
- Two wheels with brakes and two without.

Construction

banquet trolleys 2 kW



KUSİNA İNŞAAT TAAHHÜT MUTFAK TUR. SAN. VE DIŞ TİC. LTD. ŞTİ.

Genel Merkez & Head Office : Yahya Kahya Mh. Kasımpaşa Bostanı Sk. No:1 Kasımpaşa- Beyoğlu - İSTANBUL

Tel Fax & Phone Fax: +90 212 361 45 12

Fabrika & Factory : Bahçelievler Mh. Sakarya Cad. No:8 35260 Yazıbaşı / Torbalı – İZMİR

Tel & Phone : +90 232 853 92 00 (pbx) Fax : +90 232 853 91 99

www.kusina.com.tr

**MADE IN
TURKEY**

Banquet Trolleys 2 Kw GBA100H

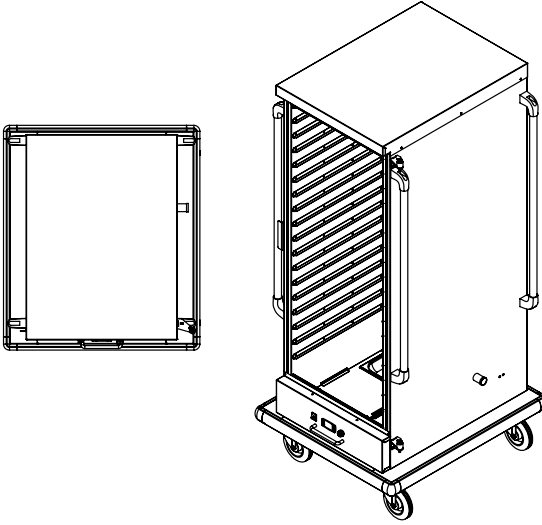
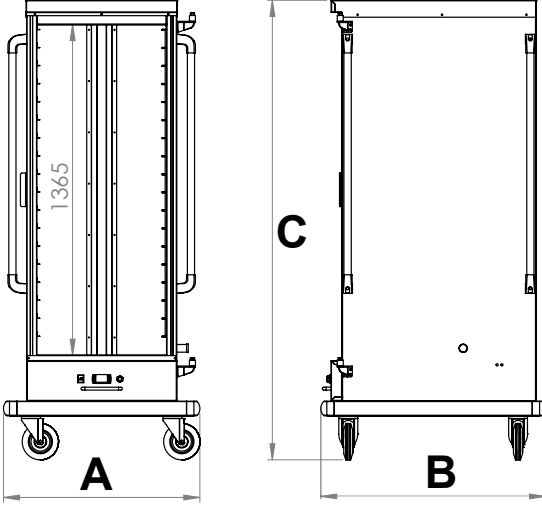

Kod-Code	GBA100H
Genişlik - Widht (A)	811
Derinlik - Dept (B)	928
Yükseklik - Hight (C)	1905
Tepsi Kapasite - Try Capacity	18 Pcs Gn 2/1x65 36 Pcs Gn 1/1x65
Elektrik Giriş - Electrical Inlet	230 V N PE
Güç - Power	2 KW
Ağırlık- Weight (kg)	141
Hacim - Volume (m3)	1,70