

fryer 15 kW

G7F100G



fryer 15 kW

G7F100G

Short Form Specification

Name: _____

Item: _____

Model: _____

Main Features

- Stainless steel body
- Easy to clean and hygienic
- Safety gas valve
- Ergonomic design
- Adjustable legs
- Long life
- High efficiency burner
- Homogenous cooking surface
- Available lpg or natural gas

Product Highlighting Details

- Single or double container models
- Unscratchable and stainless enameled cast back grate
- Fryer with cupboard
- Piezo-electric burner ignition
- Thermostatic temperature control
- Stainless steel baskets
- Adjustable temperature
- High efficient gas combustion system
- Operation and heating control indicator lights
- Stainless steel tube heaters
- Operating temperature range (0-180 ° C)

Construction

APPROVAL: _____

fryer 15 kW

G7F100G

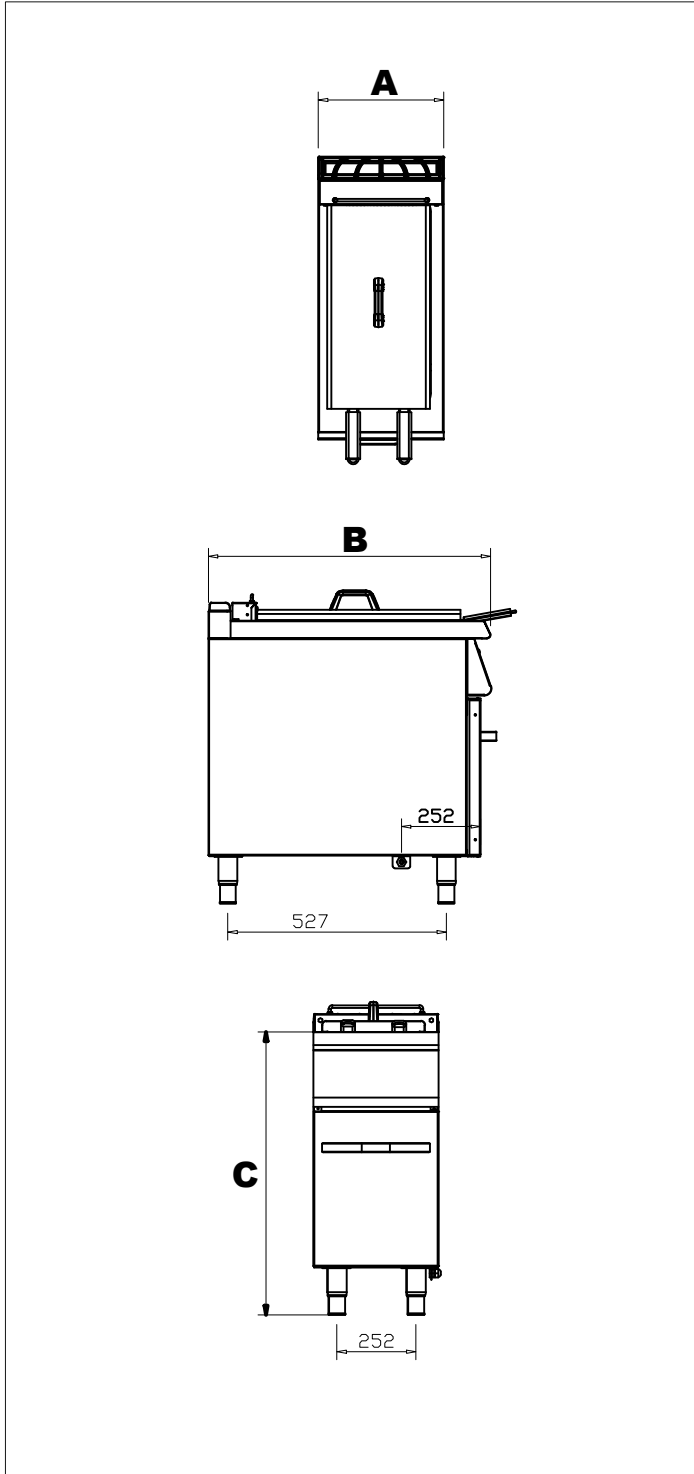

Code	G7F100G
Width (A)	400
Dept (B)	730
Hight (C)	900
Gas Inlet	R 1/2"
Power	15 kW
Weight (kg)	64
Volume (m ³)	0,45
Oil Capacity (Lt)	15