

fry top smooth 6 kW

G9I100E



fry top smooth 6 kW

G9I100E

Short Form Specification

Name: _____

Item: _____

Model: _____

Main Features

- Stainless steel body
- Easy to clean and hygienic
- Ergonomic design
- Adjustable legs
- Long life
- High efficiency burner
- Available LPG or natural gas

Product Highlighting Details

- Smooth, ribbed and ½ smooth + ½ ribbed fry top plates versions
- Fry top with cupboard
- ST 52 steel or hard chromium coated steel 15 mm thick griddle plate
- Cooking surface perimeter is 3 mm thick stainless steel
- Stainless steel oil collection drawer is placed in cupboard
- Slightly sloped cooking surface, easy and convenient for cleaning, with liquid discharge hole.
- Homogenous heated cooking surface
- Special machined grooves
- Waste oil drawer
- Thermostatic temperature control
- Thermocouple safety device connected to the burner
- Piezo-electric burner ignition
- Double independent cooking surface
- Insulation to prevent overheating of the body and reduce energy losses
- Operating temperature range (50-300 ° C)

Construction

APPROVAL: _____

fry top smooth 6 kw

G9I100E

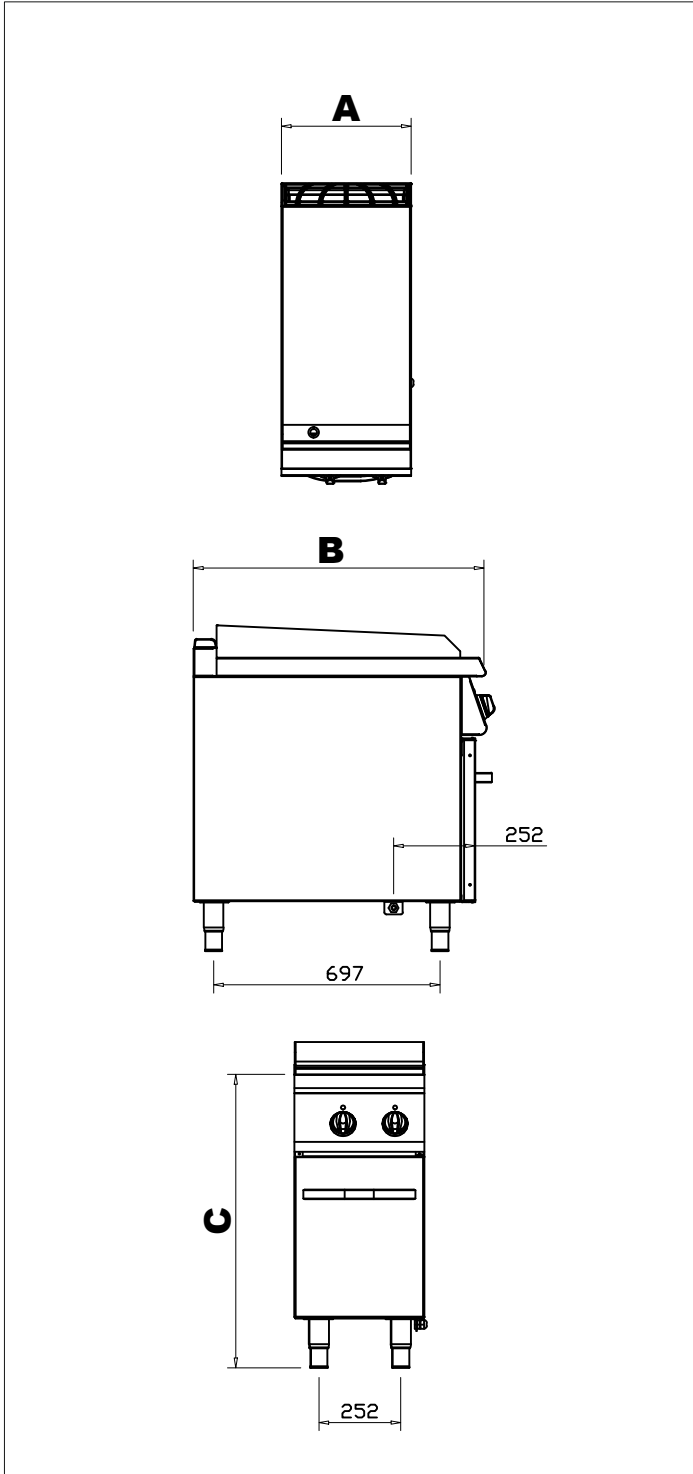

Code	G9I100E
Width (A)	400
Dept (B)	900
Hight (C)	900
Electrical Inlet	400 V 3N PE
Power	6 kW
Weight (kg)	60
Volume (m ³)	0,56