

tilting bratt pan 9 kW

## G7TD200E



tilting bratt pan 9 kW

G7TD200E

### Short Form Specification

Name: \_\_\_\_\_

Item: \_\_\_\_\_

Model: \_\_\_\_\_

### Main Features

- Stainless steel body.
- Easy to clean and hygienic.
- Ergonomic design.
- Adjustable legs.
- Long life

### Product Highlighting Details

- Stainless steel cooking pan
- While tilting bratt pan switch step in, system stops
- Safety thermostat
- Pilot light and valve with thermocouple
- Piezo-electric burner ignition
- Water filling pipe controlled from front panel
- Self hinged lid
- 200 mm depth stainless steel pan
- Unscratchable zenameled cast iron back grate
- Thermostatic temperature control
- Tubular burner placed under the tank
- Adjustable heating system 50°C - 300°C
- Hand –wheel boost system

### Construction

APPROVAL: \_\_\_\_\_

# KUSINA

tilting bratt pan 9 kW

## G7TD200E

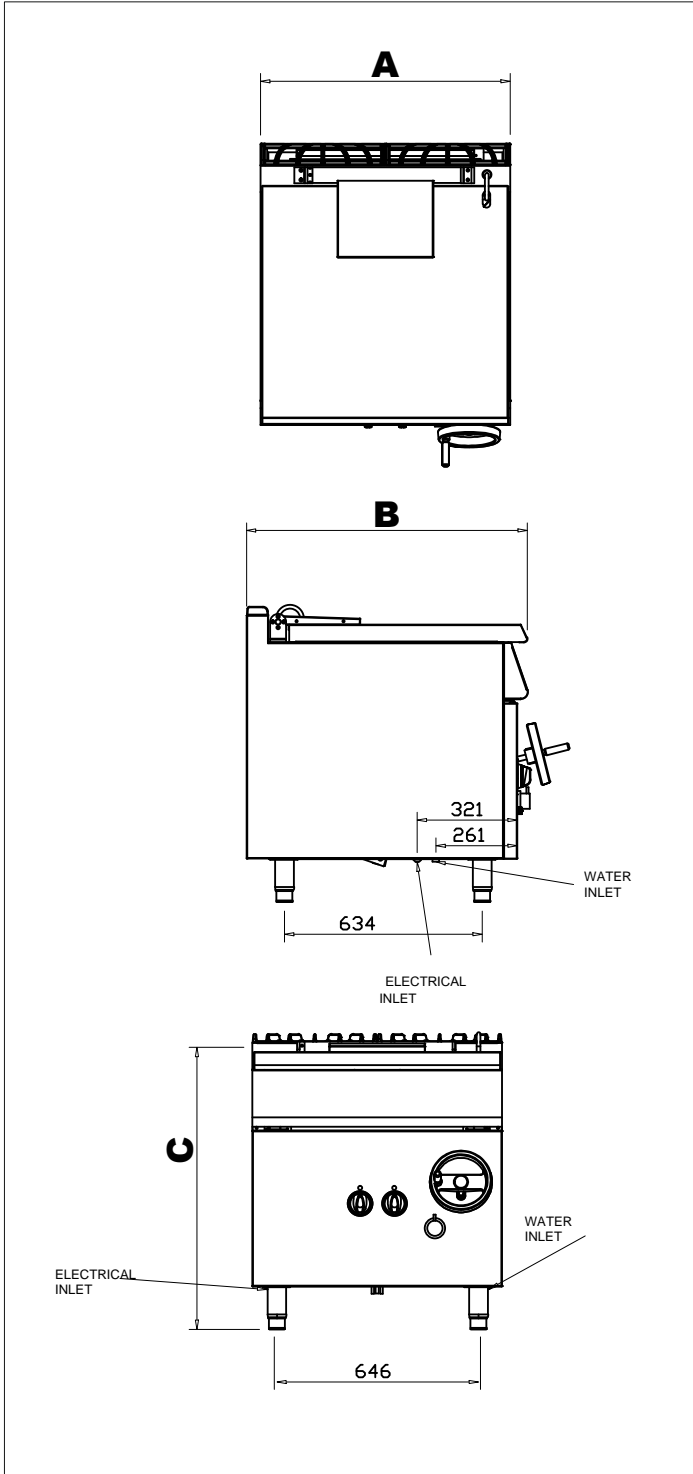

Code	G7TD200E
Width (A)	800
Dept (B)	730
Hight (C)	900
Electrical Inlet	400V 3N PE
Power	9 kW
Weight (kg)	130
Volume (m <sup>3</sup> )	0,95
Capacity (Lt)	60

CE

All rights reserved.