

Electrical Range 13 kW

G7K210E



Electrical Range 13 kW

G7K210E

Short Form Specification

Name: _____

Item: _____

Model: _____

Main Features

- Stainless steel body.
- Easy to clean and hygienic.
- Ergonomic design.
- Adjustable legs.
- Long life, easy to operate and maintenance.
- Detachable and clearable easily oven tray shelves.
- Easy to changeable door joint.

Product Highlighting Details

- 2 or 4 heating plates, with or without oven models
- \varnothing 180 mm and \varnothing 230 mm -two types of cooking plates
- Unscratchable enameled cast iron back grate
- With oven or cupboards
- Oven available for 2/1 GN trays
- Enamel coated bottom steel sheet
- The body of the oven is made of aluminium coated sheet metal
- Stainless steel double-wall, insulated door
- Stainless steel tube heaters
- Adjustable thermostatic temperature control
- Indicator lights when reaching to the required temperature

Construction

APPROVAL: _____

Electrical Range 13 kW

G7K210E

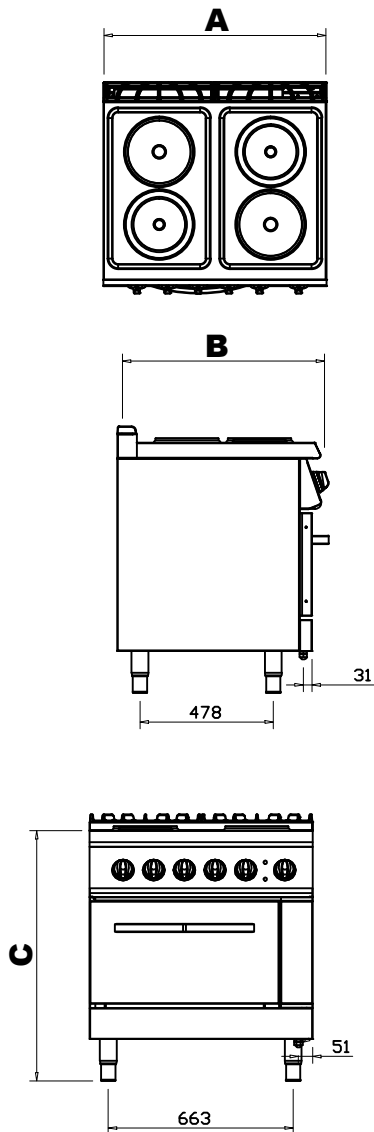

Code	G7K210E
Width (A)	800
Dept (B)	730
Hight (C)	900
Electrical Inlet	400 V 3N PE
Power	13 kW
Weight (kg)	140
Volume (m ³)	0,84