

fry top smooth 7,2 kW

G7I200E



fry top smooth 7,2 kW

G7I200E

Short Form Specification

Name: _____

Item: _____

Model: _____

Main Features

- Stainless steel body.
- Easy to clean and hygienic.
- Ergonomic design.
- Adjustable legs.
- Long life, easy to operate and maintenance.
- Homogenous cooking surface and special processed grooves.

PRODCUT HIGHLIGHTING DETAILS

- Smooth, ribbed and ½ smooth + ½ ribbed fry top plates versions
- Fry top with cupboard
- ST 52 steel or hard chromium coated steel 15 mm thick griddle plate
- Cooking surface perimeter is 3 mm thick stainless steel
- Stainless Steel Oil collection drawer is placed in cupboard
- Slightly sloped cooking surface , easy and convenient for cleaning, with liquid discharge hole.
- Homogenous heated cooking surface
- Special machined grooves
- Waste oil drawer
- Thermostatic temperature control
- Thermocouple safety device connected to the burner
- Piezo-electric burner ignition
- Double independent cooking surface
- Insulation to prevent overheating of the body and reduce energy losses
- Operating temperature range (50-300 ° C)

APPROVAL: _____

KUSINA

fry top smooth 7,2 kw

G71200E

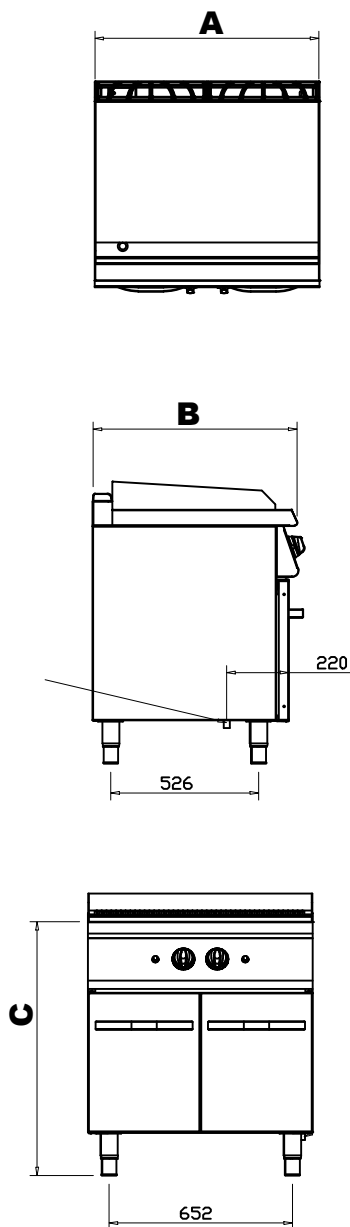

Code	G71200E
Width (A)	800
Dept (B)	730
Hight (C)	900
Electrical Inlet	400 V 3N PE
Power	7,2 kW
Weight (kg)	140
Volume (mm ³)	0,84

CE

All rights reserved.