

fryer 15 kW

## G7F100E



fryer 15 kW

**G7F100E**

### Short Form Specification

Name: \_\_\_\_\_

Item: \_\_\_\_\_

Model: \_\_\_\_\_

### Main Features

- Stainless steel body
- Easy to clean and hygenic
- Safety gas valve
- Ergonomic design
- Adjustable legs
- Long life
- High efficiency burner
- Homogenous cooking surface
- Available lpg or natural gas

### Product Highlighting Details

- Single or double container models
- Unscratchable and stainless enameled cast back grate
- Fryer with cupboard
- Piezo-electric burner ignition
- Thermostatic temperature control
- Stainless steel baskets
- Adjustable temperature
- High efficient gas combustion system
- Operation and heating control indicator lights
- Stainless steel tube heaters
- Operating temperature range (0-180 ° C)

APPROVAL: \_\_\_\_\_

fryer 15 kW

## G7F100E

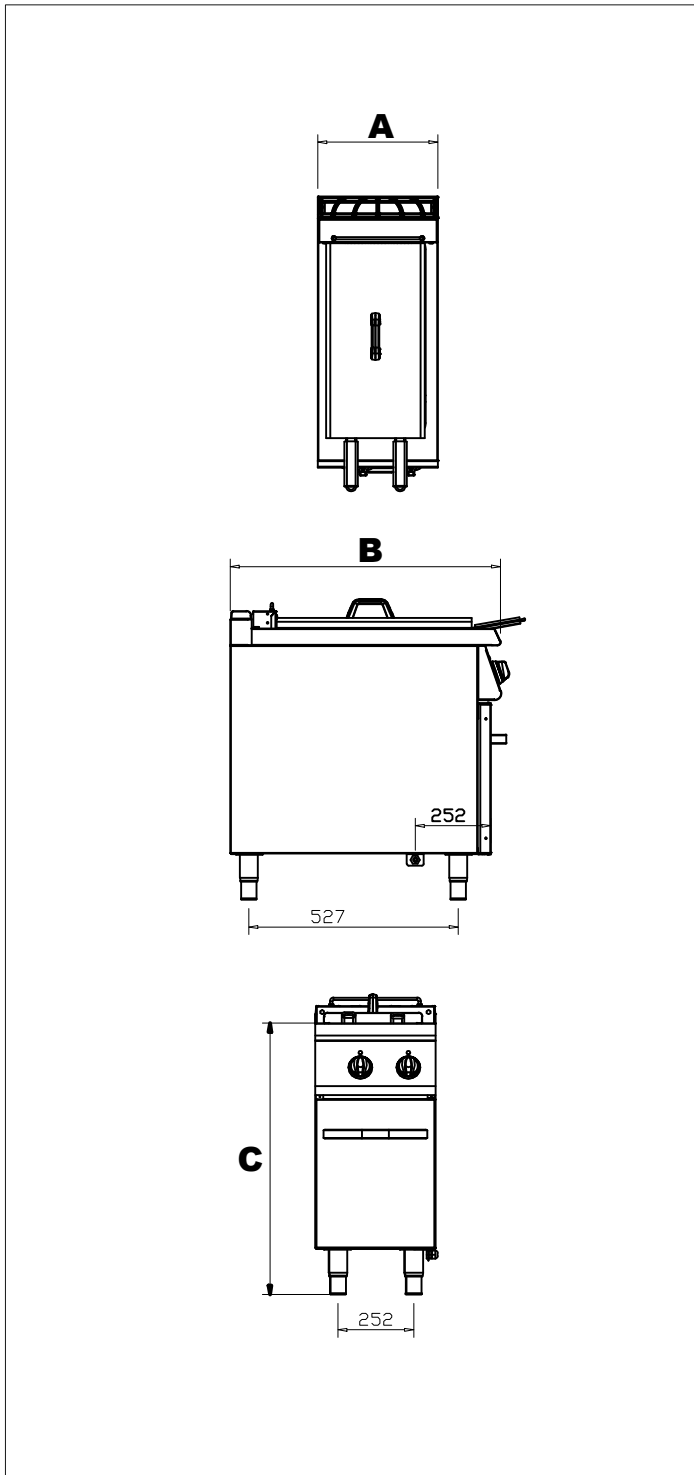

Code	G7F100E
Width (A)	400
Dept (B)	730
Hight (C)	900
Electrical Inlet	400 V 3 N PE
Power	15 kW
Weight (kg)	55
Volume (mm <sup>3</sup> )	044
Oil Capacity (Lt)	20