

Instruction and Maintenance Manual

RANGE GAS

KUSINA

“Professionally with Professionals”

DESCRIPTION

- The instructions in this manual contain important information on the safe mounting, usage, cleaning and maintenance of the device. Thus, keep the manual at a place easily accessible by the person who will use the machine, and the technician.
- Mounting, conversions for different gas groups or electrical inlet, and maintenance works of the device should be performed by a specialist authorized in this subject and in accordance with the instructions of the manufacturer company.
- Gas and electrical connections of the device should be arranged according to the tables and electrical diagram given in this manual.
- Manufacturer Company accepts no responsibility for the final damages incurred in humans or properties that are caused by any procedure not conforming to the instruction manual, or maintenance or technical interventions that are not performed by authorized people.

TYPES

- G6K100G – 600 serie ½ module counter top
- G6K200G – 600 serie 1 module counter top
- G7K100G – 700 serie ½ module w/ cupboard
- G7K200G – 700 serie 1 module w/ cupboard
- G7K201G – 700 serie 1,5 module w/ cupboard
- G7K210G – 700 serie 1 module w/oven
- G7K211G – 700 serie 1,5 module w/ cupboard and oven
- G9K100G – 900 serie ½ module w/ cupboard
- G9K200G – 900 serie 1 module w/ cupboard
- G9K201G – 900 serie 1,5 module w/ cupboard
- G9K210G – 900 serie 1 module w/oven
- G9K211G – 900 serie 1,5 module w/ cupboard and oven
- G9K212G – 900 serie 1,5 module w/ oven

MOUNTING INSTRUCTION

Placement

- Installation and adjustment of the device should be carried out by technical staff of the Authorized Service.
- Place the device at a place min. 10cm away from the side or back wall to prevent excessive temperature rises.
- Place the device beneath a filtered exhaust hood in order to eliminate smell and fume that may be emitted during cooking.
- Device should be placed on a flat surface by suitably balancing on the four adjustable legs. (Figure A)
- Remove the protective nylon on the device. Clean the adhesive particles left on the device with a suitable cleaner.
- Never leave flammable material near the device.

GAS CONNECTION

- Device should be connected in accordance with the national and local gas standards of the relevant country.
- Gas inlets “G” of the device are indicated with a label on device body.
- Connection to the gas installation should be made with flex pipe and ball valve. Fix the said ball valve to a place that is away from heat and easily accessible in case of a danger.
- After gas inlet connection is completed, check for possible gas leakages.

- Feed the device with the gas and pressure as specified on device information plate and adjusted. If the gas type to which the device was adjusted for is not suitable to the gas type at the mounted place, follow the instructions written below.

ATTENTION: All adjustments and modifications to be performed on the gas installation and connection of the device should be performed by authorized people.

ADJUSTMENT ACCORDING TO DIFFERENT GAS TYPES

- If the device is connected to gas installation, close main gas inlet valve.
- Replacement of top burner nozzles (Figure B)
 - a. Remove cooker grater(1), top burner cover (2) and oil tray (3) (G6K-100-200G-G7-9K100-200-201-210-211G)
 - b. Replace nozzle (5) with a nozzle suitable for the gas type
 - c. Adjust the flame of the pilot burner by turning the bolt (4)
- Replacement of oven nozzles (Figure C , D) (G7-9K210-211-212G)
 - a. Take out lower metal sheet (6) of oven door by removing its bolts (7) (Figure C)
 - b. Replace oven nozzle (8) with a nozzle suitable for the gas type (Figure D)
 - c. Replace pilot nozzle of oven pilot burner (9) with a nozzle suitable for the gas type (Figure D)

OPERATOR INSTRUCTIONS AND ATTENTION POINTS



- With the aim of eliminating the malodour and fume caused by the isolation of the stove oven, adjust the oven thermostat to the highest value in the first start-up and operate it unloaded for a while with its door open.
- Gas taps of cooker and oven has safety valve; if the main flame goes out for any reason, gas flow is cut off automatically.
- Do not cook on cookers with the lower oil pan removed.
- Do not operate the oven with its back funnel mouldings removed or closed.

STARTING-UP COOKERS (700-900 Serie)

- Turn the main gas valve to open position.
- Turn the cooker gas button to pilot flame position “  ” by pushing it gently and ignite the pilot

with an external flame source from the hole near the cooker burner.



- After the pilot is ignited, keep the button pressed for a few seconds min. 10 to heat the safety thermocouple end.

- Later, you can adjust it to the desired position by turning to half “  ” or full flame “  ”
- If the device is operated for the first time, keep the button pressed at pilot burner flame position for a while before ignition to discharge the air in the gas installation.

STARTING-UP COOKERS (600 Serie)

- Turn the main gas valve to open position.
- Turn the cooker gas button to pilot flame position “  ” by pushing it gently and ignite the pilot

with an external flame source from the hole near the cooker burner.

- Later, you can adjust it to the desired position by turning to half “  ” or full flame “  ”
- If the device is operated for the first time, keep the button pressed at pilot burner flame position for a while before ignition to discharge the air in the gas installation.

TURN OFF (700-900 Serie)

- Turn the cooker gas button to pilot flame position “”, only pilot burn occurs. Turn to position “0” to turn off completely.

TURN OFF (600 Serie)

- Turn to position “0” to turn off completely.

STARTING-UP THE OVEN (Figure E) (700-900 Serie)

- Turn to the side part (11) to see the pilot burner
- Turn the oven button (13) to pilot position by pressing it gently
- Push button (14) and Ignite the pilot by pushing the button (12). Keep pressed button (14) for a few seconds (min. 10) to heat the safety thermocouple end.
- Then, you can adjust the heat by turning the button left according to the temperature degrees indicated on the scale of button (11)

TURN OFF

- Turn oven or its button to pilot position. In this position, only pilot burn occurs. Turn to position “0” to turn off completely.
- Push button (15) then it will be off the oven
- Wait min. 2 min before ignite the oven if turn off it by pushing button 15

MAINTENANCE

- Never perform maintenance without closing the main gas valve of the device.
- Before it cools down completely, wipe the device with a cloth immersed in warm soapy water.
- Do not use cleaning substances and tools that may cause scratches on device surface.
- If required, use chemical cleaners.
- Do not clean the device with pressurized water or vapour.
- Take out lower oil trays of oven and oven grates, and clean them with warm water and soap daily.
- If the device will not be used for a long period, coat the surfaces with a thin layer of Vaseline.

ATTENTION: Any part replacement that may affect safety must be carried out by the authorized people. During maintenance and repair, keep the main gas valve closed and keep away fire. Always perform leakage check after repair or part replacement; use foam or gas detector for this aim. In case of any dangerous condition with the device, notify to the authorized service. Do not allow unauthorized people to interfere in the device.

DANGEROUS: Never allow leakage check to be performed with flame.

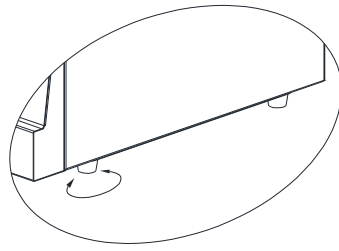
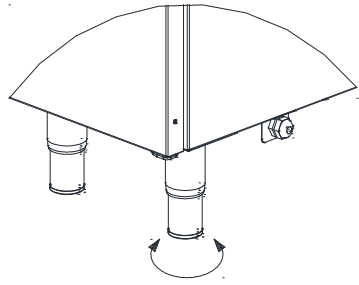
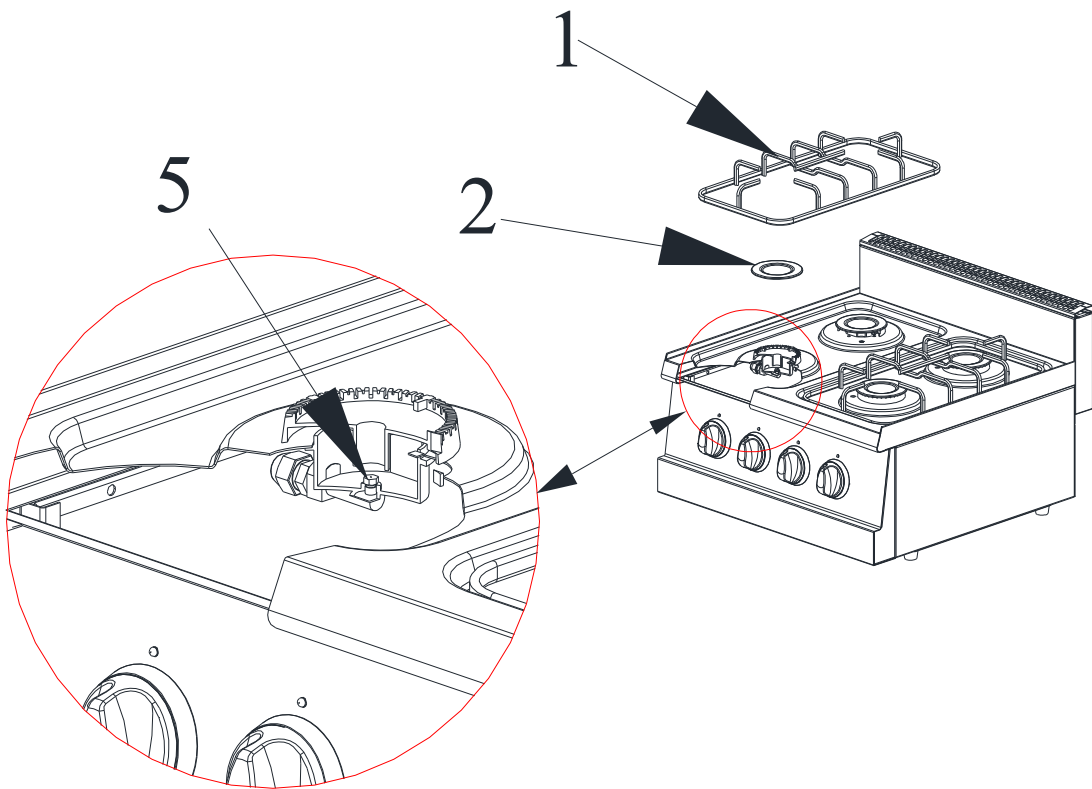
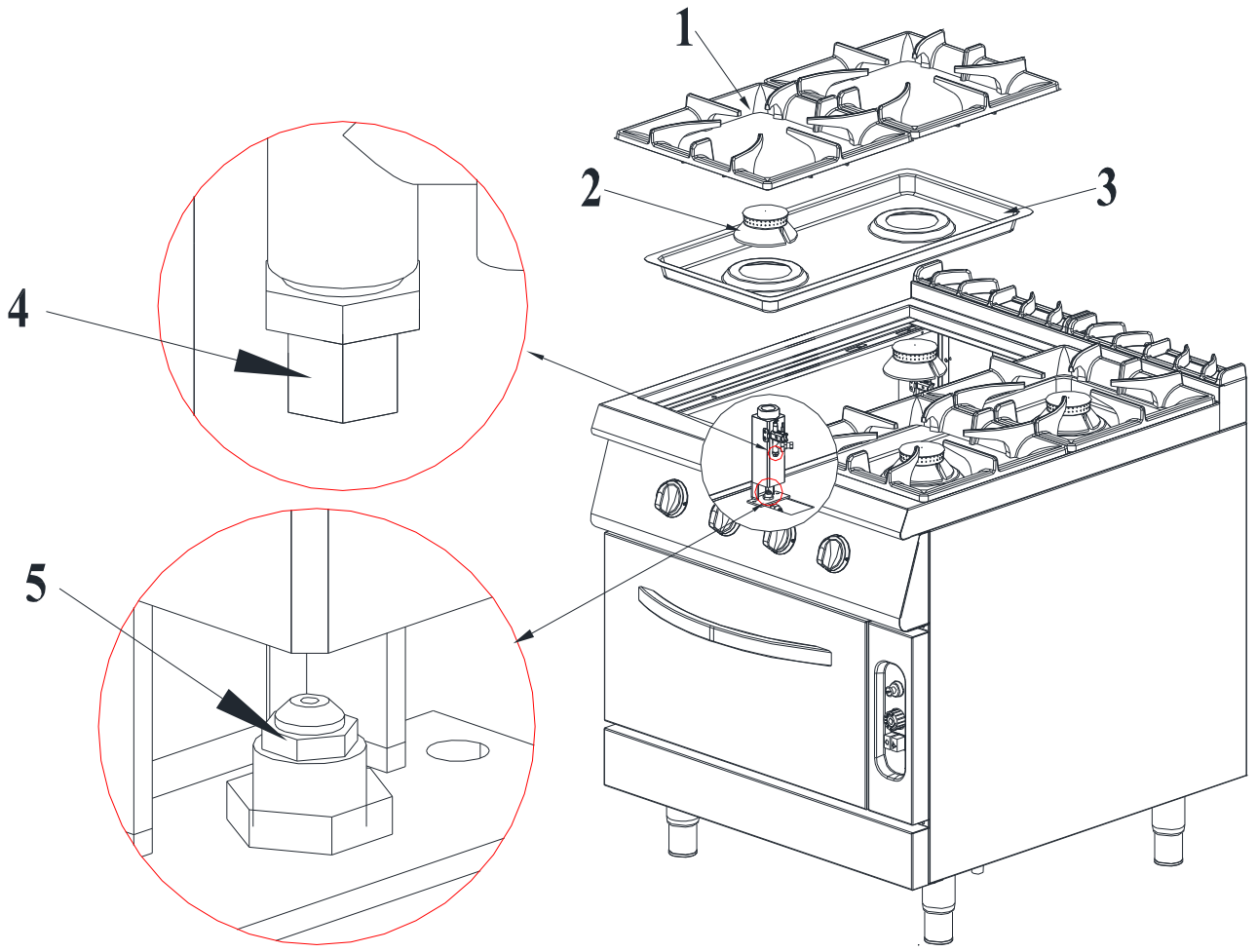
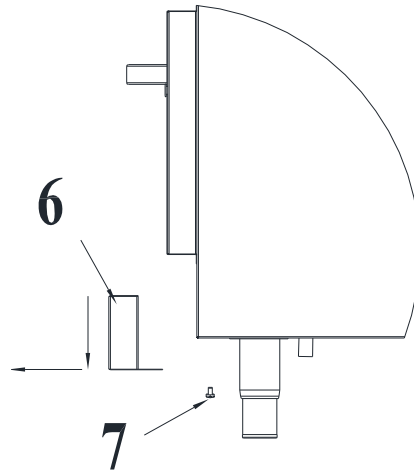

Figure A





Şekil B
Figure B



Şekil C
Figure C

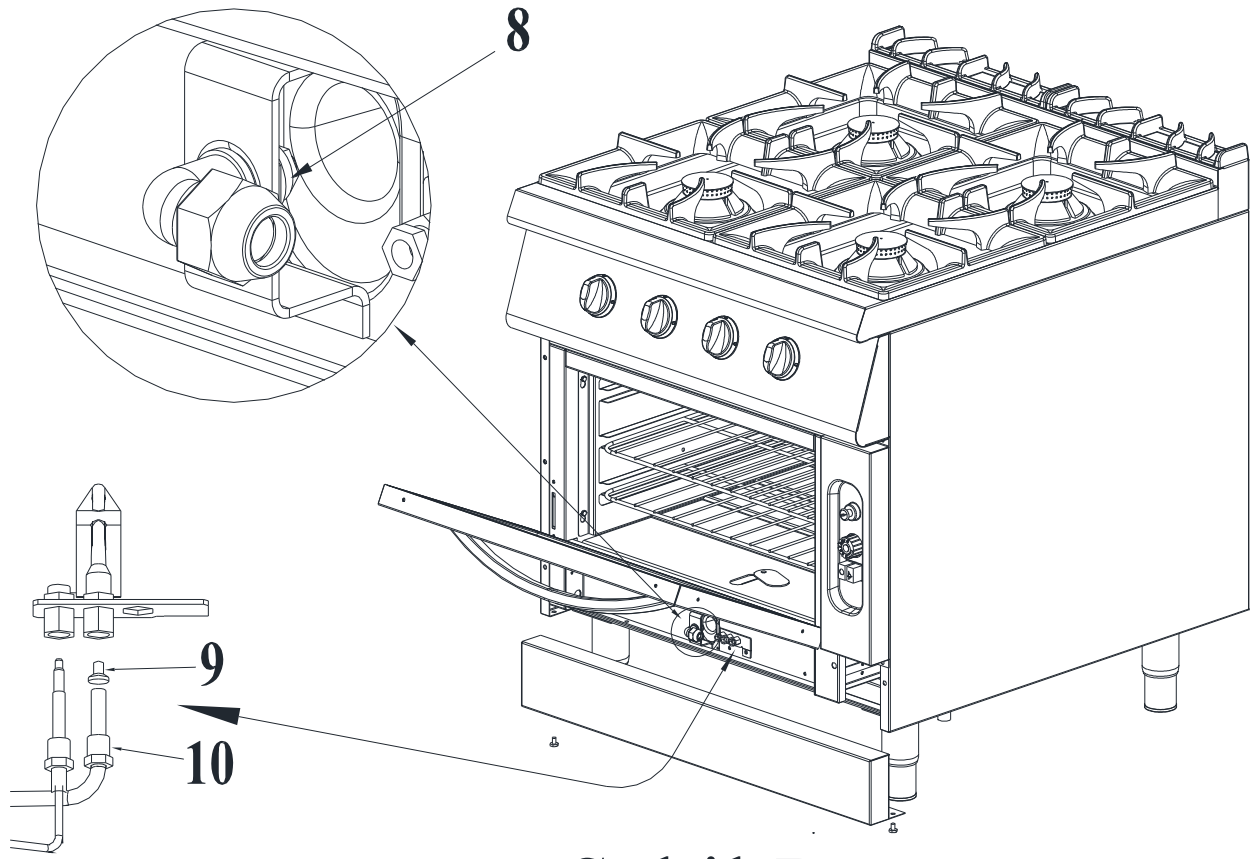

Şekil D
Figure D

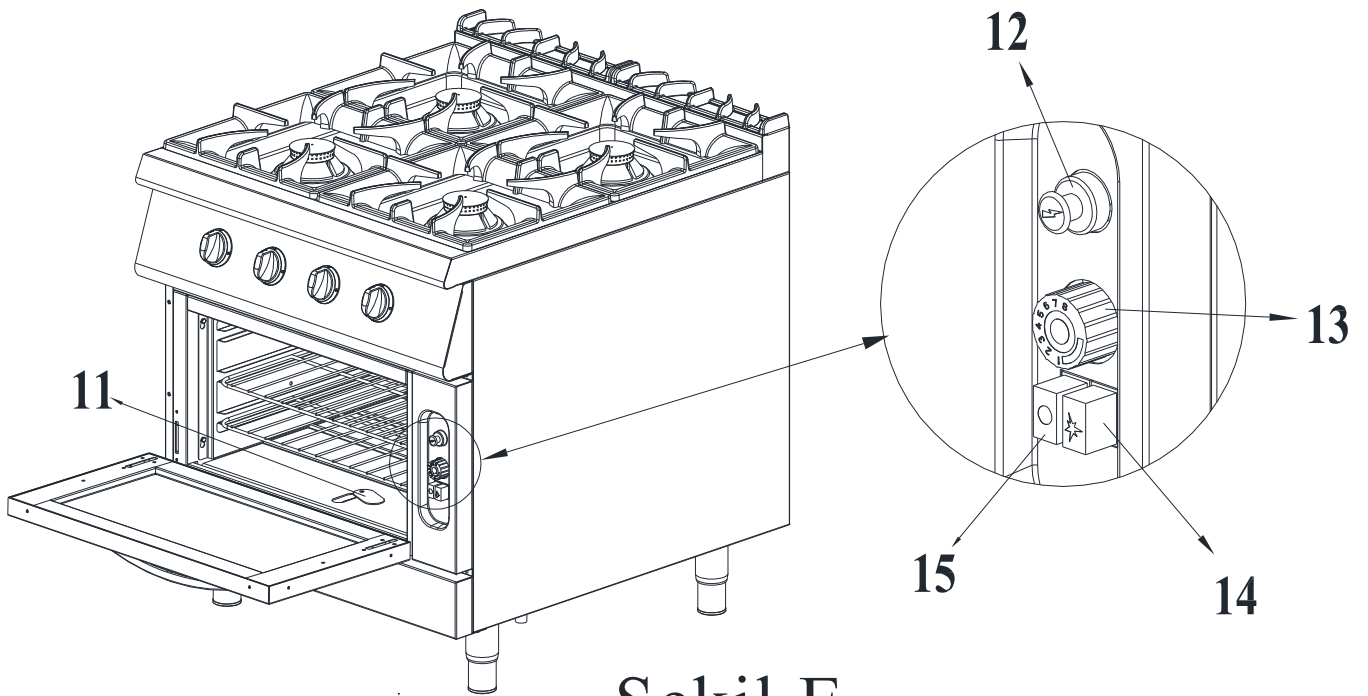

Şekil E
Figure E

G7K100G

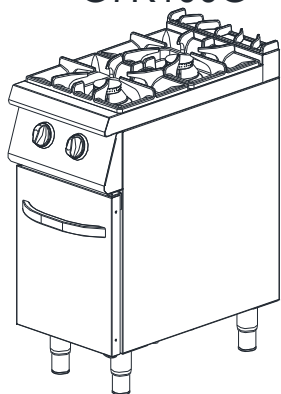

G7K200G

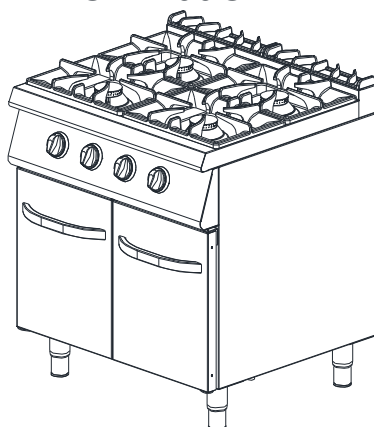

G7K210G

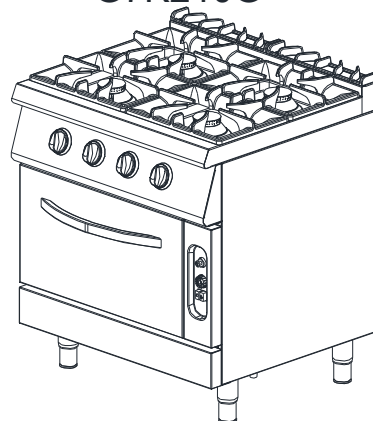

G7I211G

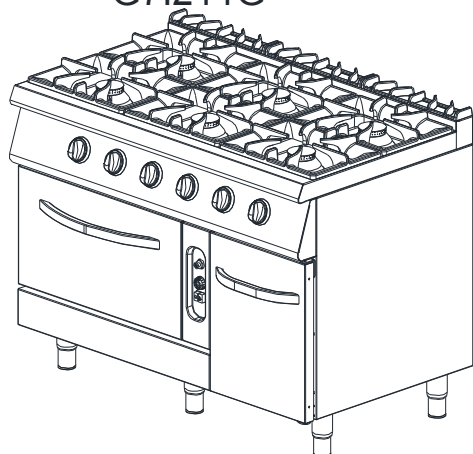

G7K212G

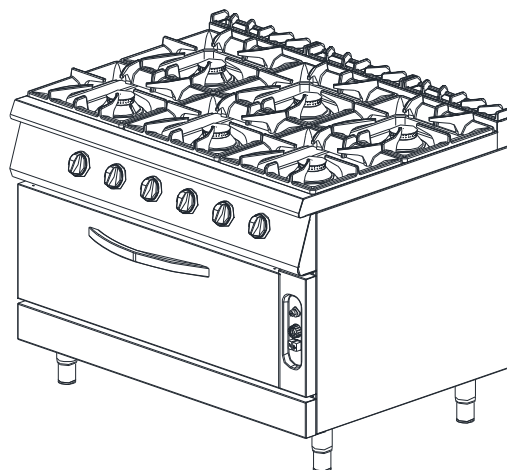

G9K100G

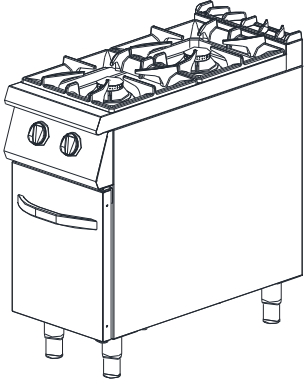

G9K200G

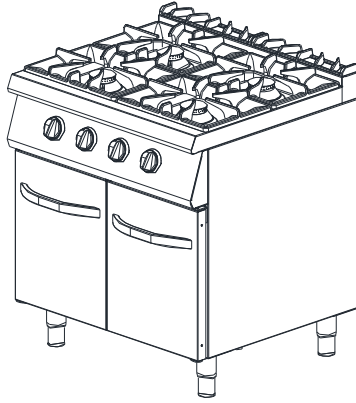

G9K210G

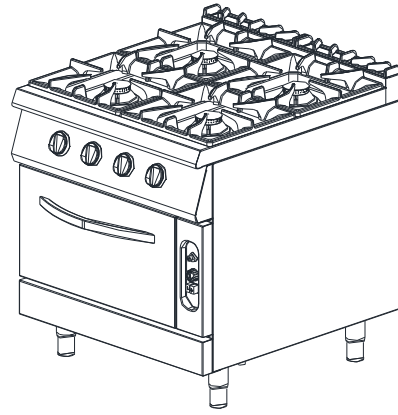

G9K201G

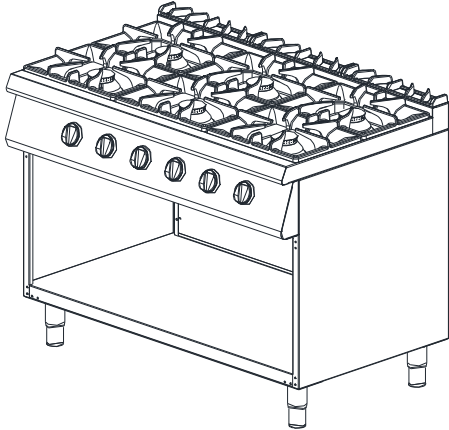

G9K211G

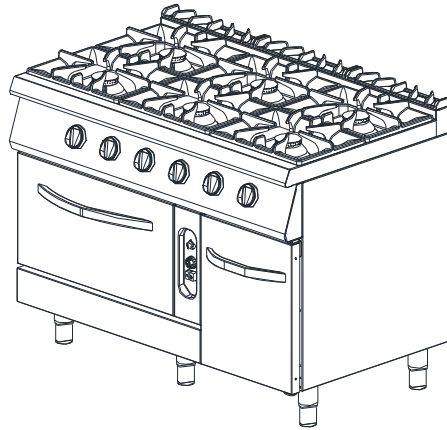

G9K212G

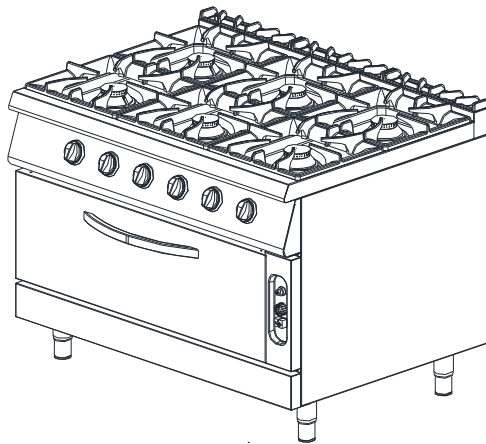

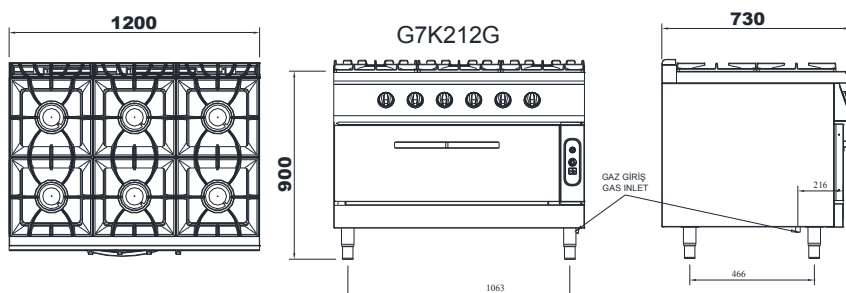
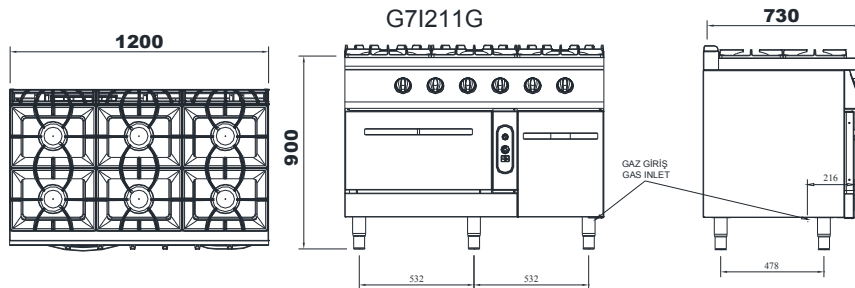
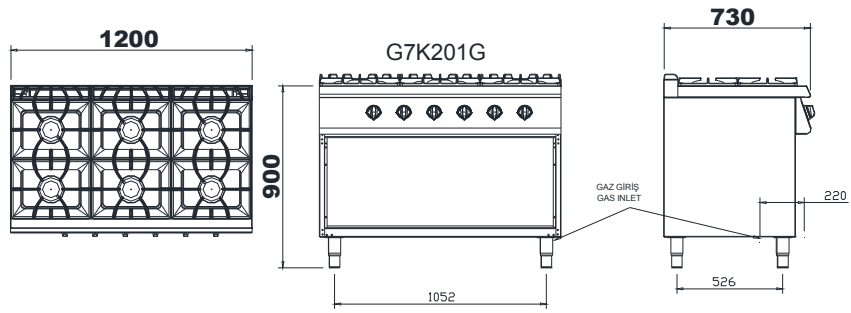
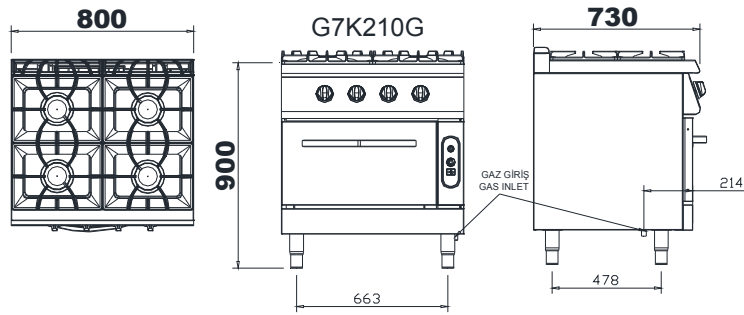
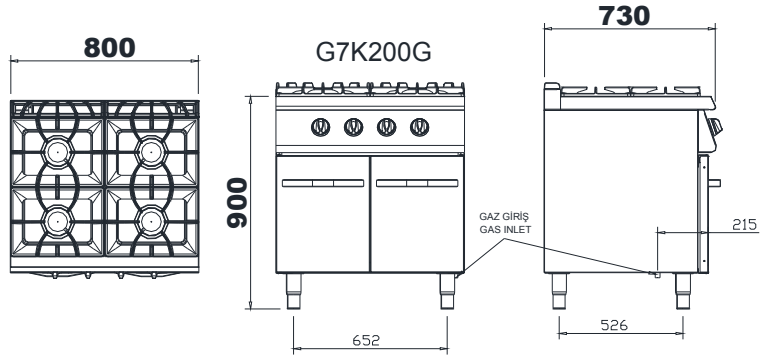
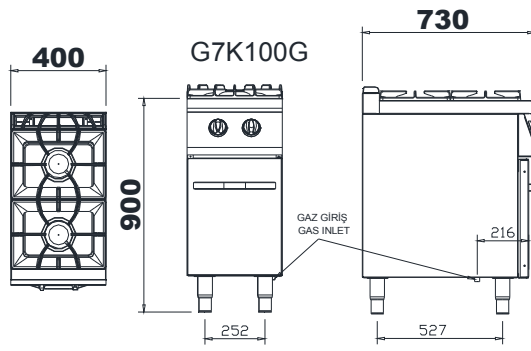



G9K100G

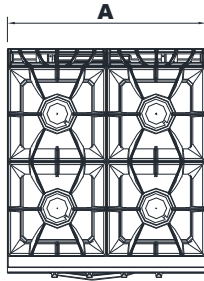
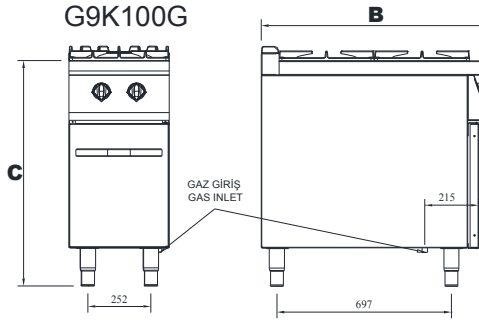

G9K200G

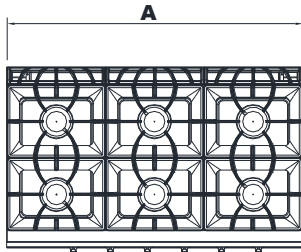
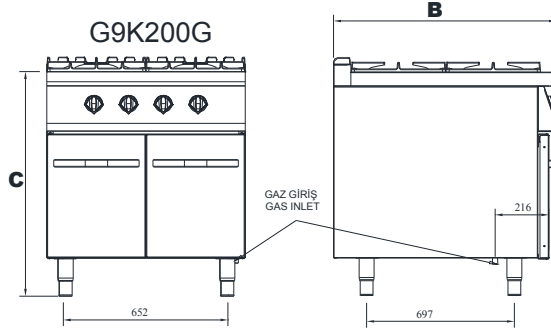

G9K201G

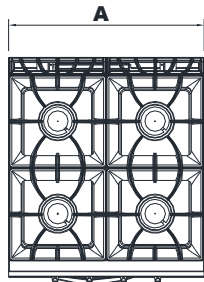
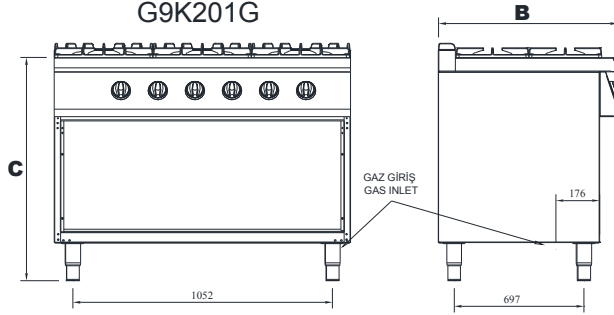

G9K210G

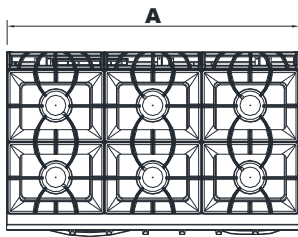
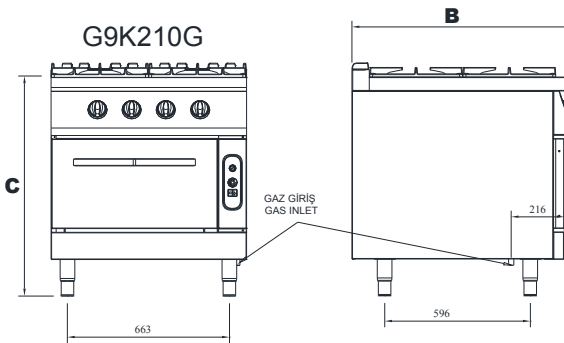

G9K211G

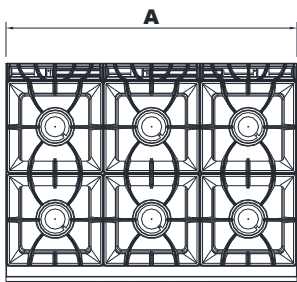
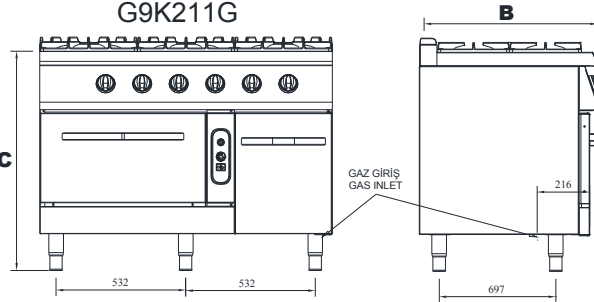

G9K212G

