

INSTRUCTION AND MAINTENANCE MANUAL

FRYER (GAS)

KUSINA

“Professionally with Professionals”

DESCRIPTION

- The instructions in this manual contain important information on the safe mounting, usage, cleaning and maintenance of the device. Thus, keep the manual at a place easily accessible by the person who will use the machine, and the technician.
- Mounting, conversions for different gas groups or electrical inlet, and maintenance works of the device should be performed by a specialist authorized in this subject and in accordance with the instructions of the manufacturer company.
- Gas and electrical connections of the device should be arranged according to the tables and electrical diagram given in this manual.
- Manufacturer Company accepts no responsibility for the final damages incurred in humans or properties that are caused by any procedure not conforming to the instruction manual, or maintenance or technical interventions that are not performed by authorized people.

TYPES

- G6F100G – 600 series gas fryers
- G7F100G –G7F200G – 700 series gas fryers
- G9F100G –G9F200G – 900 series gas fryers

MOUNTING INSTRUCTIONS

- Installation and adjustment of the device should be carried out by technical staff of the Authorized Service.
- Place the device beneath a filtered exhaust hood in order to eliminate smell and fume that may be emitted during cooking.
- Place the device at a place min. 10cm away from the side or back wall to prevent excessive temperature rises.
- Device should be placed on a flat surface by suitably balancing on the four adjustable legs. (Figure A)
- Remove the protective nylon on the device. Clean the adhesive particles left on the device with a suitable cleaner.
- Never leave flammable material near the device.

GAS CONNECTION

- Have the gas connection of the device carried out by an authorized service employee.
- Device should be connected in accordance with the national and local gas standards of the relevant country.
- Gas inlets of the device are indicated with “GAS” label on device body.
- Connection to the gas installation should be made with flex pipe and ball valve. Fix the said ball valve to a place that is away from heat and easily accessible in case of a danger.
- After gas inlet connection is completed, check for possible gas leakages through leakage detection device or soapy water.
- Feed the device with the gas and pressure as specified on device information plate and adjusted. If the gas type to which the device was adjusted for is not suitable to the gas type at the mounted place, follow the instructions written below.

ATTENTION: All adjustments and modifications to be performed on the gas installation and connection of the device should be performed by authorized people.

ADJUSTMENT ACCORDING TO DIFFERENT GAS TYPES

- If the device is connected to gas installation, close main gas inlet valve.
- Replacement of burner nozzles (fig. B)
 1. Open the cabinet cover of the fryer. (G7F100-200G, G9F100-200G)
Unscrew the front panel (G6F100-200G)
Unscrew the nozzle (3) at the burner inlet using a suitable wrench.
 2. Replace nozzle (3) with a nozzle suitable one for the gas type.
 3. Adjust the pilot flame (1) by turning bolt nut (2)



OPERATOR INSTRUCTIONS AND ATTENTION POINTS

- Before cooking with the fryer, operate it with no load (by pouring water in its chamber) for a while. Thus, the protection oil on it will disappear and it will become ready to use.
- When you do not cook, keep the adjustment button on pilot position. It will provide a more economical usage for you.
- Never operate the fryer without oil. Check whether the chambers are full with oil before use.
- When the oil level descends to minimum, refill oil.
- If you will not use the device for a long time, cover it with suitable oil and keep away from moisture.
- Do not operate the device with its back funnel mouldings removed or closed.
- It is equipped with limit thermostat (Figure C) “2” for protection against excessive oil heating or excessively heated oil due to operating without oil (240°C). If the limit thermostat cuts off the operation, firstly wait for oil to cool, and then, open the limit thermostat cover and gently press the red button. If limit thermostat cuts off again when you reactivate, apply to the authorized service.

START-UP (G7-9F100-200G)

- Turn the main gas valve to open position.
- Turn the button (6) to position “”. (Figure C).
- Press down the button (8) and push the magnet lighter several times until the pilot ignites
- After the pilot burner is ignited, continue to keep it pressed for a few seconds (min 10 sec).
- Turn the tap button to position between 1-8 .The 8 corresponds to 190° C
- The taps operates between 110° and 190° C.
- If the device is operated for the first time, keep the button (8) pressed at pilot burner flame position for a while before ignition to discharge the air in the gas installation.

START-UP (G6F100-200G)

- Turn the main gas valve to open position.
- Turn the button (6) to highest position 7
- Gently press down the button (9) and turn clock reverse to “” signal. In the meantime the magnet lighter “” will ignite the pilot flame.
- After the pilot burner is ignited, continue to keep it pressed for a few seconds (min 8-10 sec) for thermocouple. After thermocouple heated, turn the button (9) to “” position for ignite the burner. (Fig D)
- Turn the tap button to position between 1-7 .The 7 corresponds to 190° C
- If the device is operated for the first time, keep the button (8) pressed at pilot burner flame position for a while before ignition to discharge the air in the gas installation.

TURNING OFF (G7-9F100-200G)

- Turn the button (6) to position . Then it will be just the pilot flame is lit
- To turn off fully, press the button 7 and turn off the main gas valve. In this case have to wait 2-3 min before turn it “on” again

TURNING OFF (G6F100-200G)

- Turn the button (6) to position “1”.
- Turn the pilot button (9) to pilot position “”. Then it will be just the pilot flame is lit
- To turn off fully, press the button (9) and turn off the gas. In this case have to wait 2-3 min before turn it “on” again

MAINTENANCE

- Never perform maintenance without closing the main gas valve of the device.
- Before it cools down completely, wipe the device with a cloth immersed in warm soapy water.
- Do not use cleaning substances and tools that may cause scratches on device surface.
- If required, use chemical cleaners.
- Do not clean the device with pressurized water or vapour.
- If the device will not be used for a long time, coat the surfaces with a thin layer of Vaseline.

ATTENTION: Any part replacement that may affect safety must be carried out by the authorized people. During maintenance and repair, keep the main gas valve closed and keep away fire. Always perform leakage check after repair or part replacement; use foam or gas detector for this aim. In case of any dangerous condition with the device, notify to the authorized service. Do not allow unauthorized people to interfere in the device.

DANGEROUS: Never allow leakage check to be performed with flame.

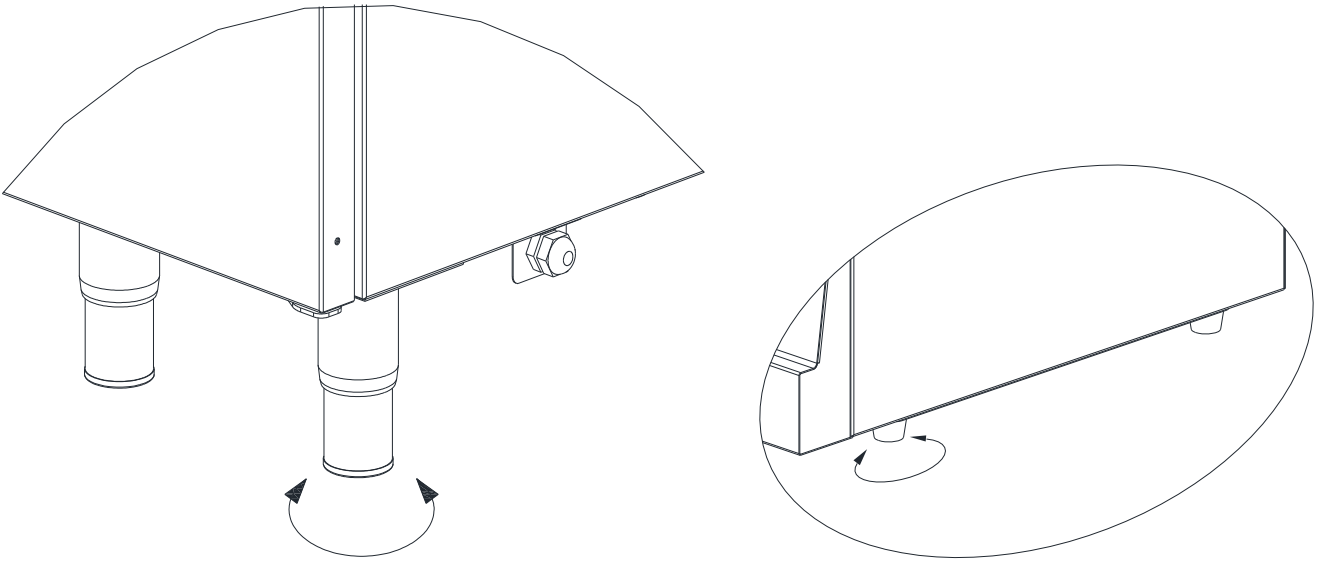

Şekil A
Figure A

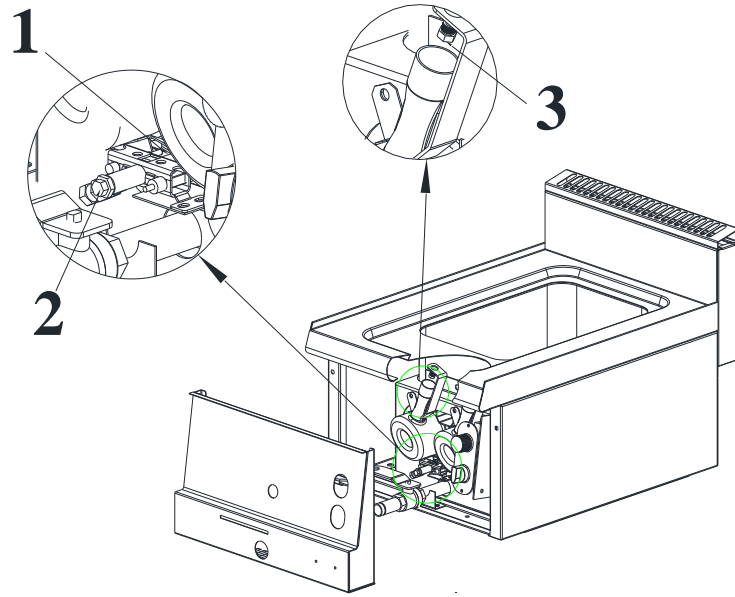

Şekil B
Figure B

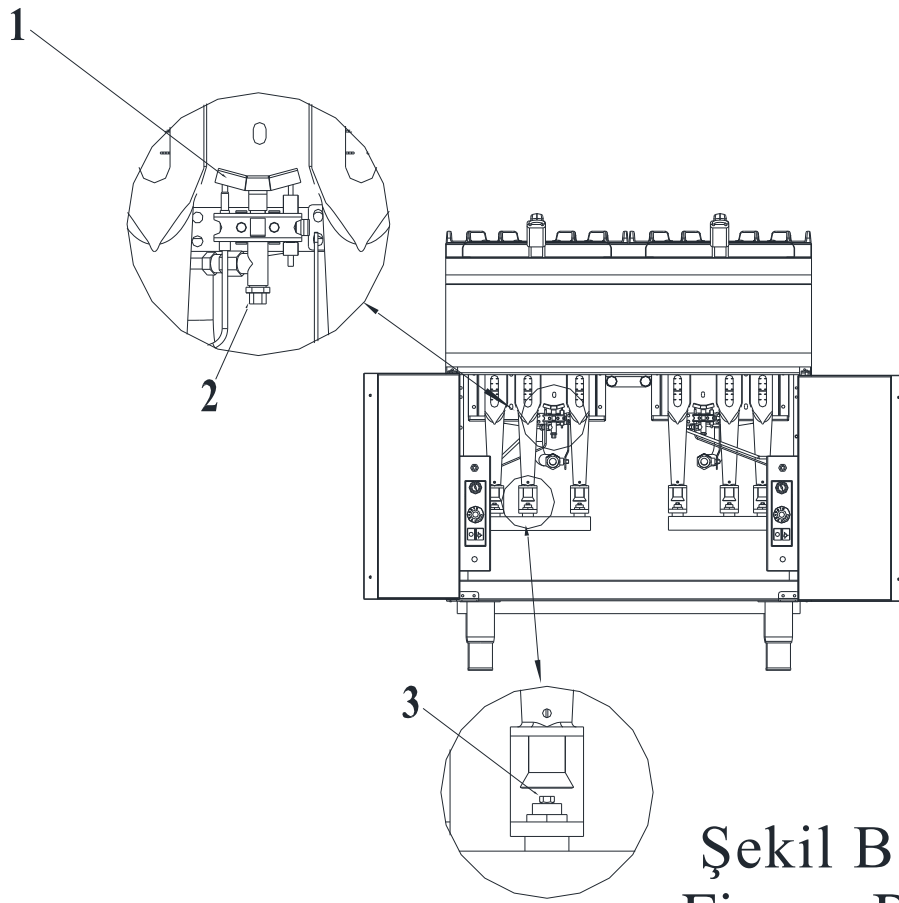

Şekil B
Figure B

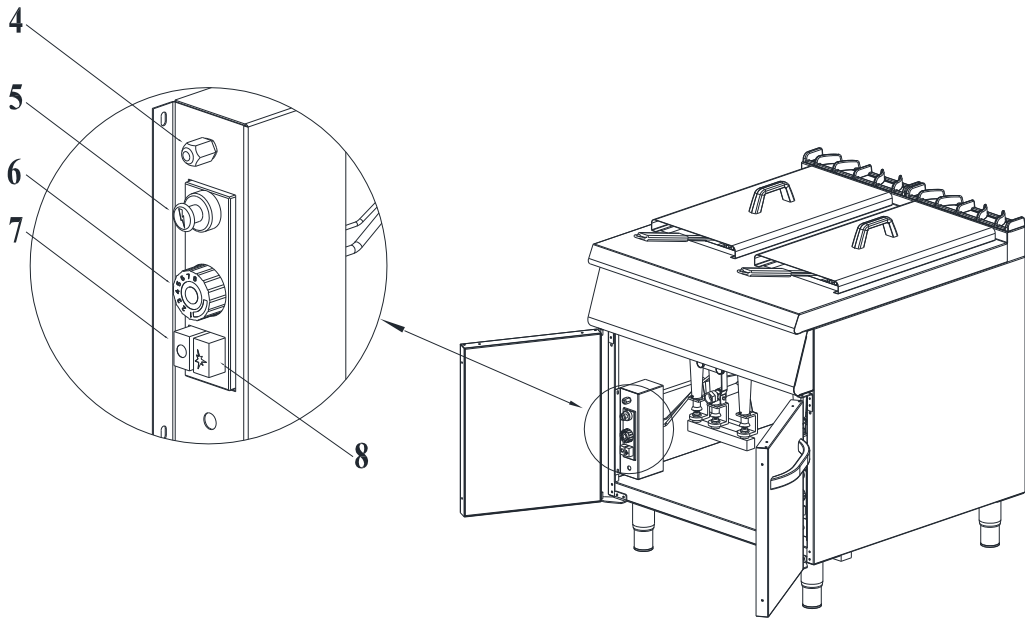

Şekil C
Figure C

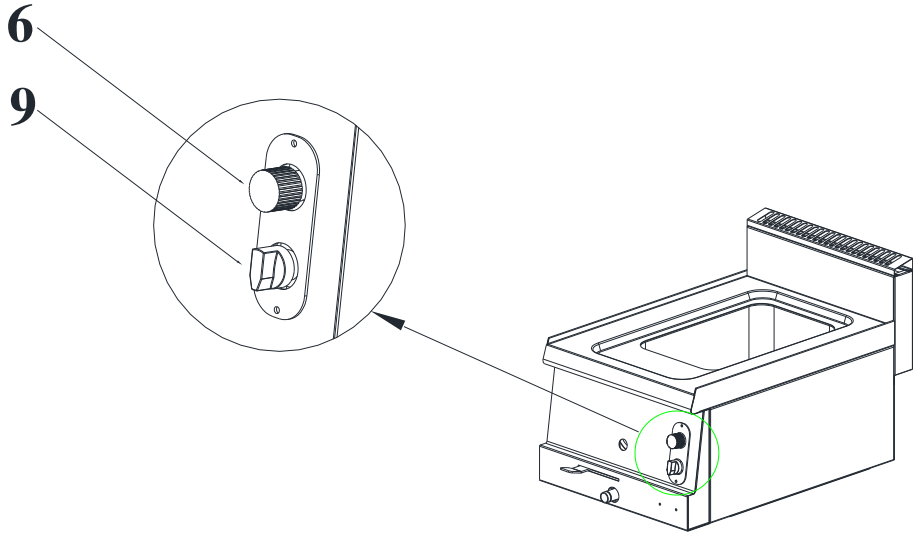

Şekil D
FigureD

