

# ***KUSINA***<sup>®</sup>

600 -700 -700S - 900 SERIES



***KUSINA***<sup>®</sup>



**600 SERIES**

# cooking

gas burner / brûleur à gaz / fogão à gás / horno a gas

# KUSINA®

## 600 SERIES



### General Features

- Stainless steel body
- Easy to clean and hygienic
- Safety gas valve
- Ergonomic design
- Adjustable legs
- Long life



### Caractéristiques Générales

- Corps en acier inoxydable
- Facile à nettoyer et hygiénique
- Valve à gaz avec soupape de sécurité
- Conception ergonomique
- Pieds réglables
- Longue durée



### Características Gerais

- Corpo de aço inoxidável
- Higiênica, fácil de limpar
- Válvula de segurança registro de gás
- Design econômico
- Pés ajustáveis
- Longa durabilidade



### Características Generales

- Estructura de acero inoxidable
- Fácil de limpiar, higiénica
- Válvula de gas, válvula de seguridad
- Diseño ergonómico
- Pies ajustables
- Larga vida útil



G6K100G

#### PRODCUT HIGHLIGHTING DETAILS

- 2 or 4 Burners
- High efficiency burner
- Special enamel coated, unscrachable, easy to clean cooker top grate

#### DÉTAILS DU PRODUIT

- 2 ou 4 brûleurs
- Brûleurs à haut rendement
- Top Grille de chauffe en revêtement en émail spécial, anti-rayures, facile à nettoyer

#### DETALHES DO PRODUTO

- Com 2 ou 4 queimadores
- Queimadores de alta eficiência
- Revestido de esmalte especial, à prova de riscos, grade de fogão de fácil limpeza

#### DETALLES DEL PRODUCTO

- 2 o 4 fuegos abiertos
- Quemadores de alta eficiencia
- Plancha sobre horno, cubierto con esmalte especial, resistente a los arañazos, fácil de limpiar,



G6K200G



Model	Visual	Dim (mm) LxDxH	Burners kW	Power	Gross Weight	Gross Volume	Gas Inlet	Price	
G6K100G		400x600x300	2x3,25		6,5 kw	17 Kg	0,18 m <sup>3</sup>	R1/2 "	401 €
G6K200G		600x600x300	4x3,25		13 kw	26 Kg	0,25 m <sup>3</sup>	R1/2 "	611 €

# cooking

electrical burner / plaque électrique  
fogão elétrico / cocina eléctrica

# KUSINA®

## 600 SERIES



### General Features

- Stainless steel body
- Easy to clean and hygienic
- Ergonomic design
- Adjustable legs
- Long life



### Caractéristiques Générales

- Corps en acier inoxydable
- Facile à nettoyer et hygiénique
- Valve à gaz avec soupape de sécurité
- Conception ergonomique
- Pieds réglables
- Longue durée



### Características Gerais

- Corpo de aço inoxidável
- Higiênica, fácil de limpar
- Válvula de segurança registro de gás
- Design econômico
- Pés ajustáveis
- Longa durabilidade



### Características Generales

- Estructura de acero inoxidable
- Fácil de limpiar, higiénica
- Válvula de gas, válvula de seguridad
- Diseño ergonómico
- Pies ajustables
- Larga vida útil



G6K100E



G6K200E

#### PRODUCT HIGHLIGHTING DETAILS

- 2 or 4  $\varnothing$ 180 mm cooking plates
- Fast heating and high efficiency
- The power of each cooking plates is 1500w or high temperature protected 1800 w cooking plates in request
- Stage adjustable heat control

#### DÉTAILS DU PRODUIT

- Chauffage rapide et haut rendement
- Chacune de plaques à une puissance de 1500 W avec sur demande possibilité de fournir des plaques de 1800 W
- Contrôle de la température progressif
- Lampes de signalisation de fonctionnement

#### DETALHES DO PRODUTO

- Aquecimento rápido e de alta eficiência
- Cada placa com 1500 w de potência ou opcional proteção contra calor extremo de 1800 w
- Controle gradual de temperatura

#### DETALLES DEL PRODUCTO

- Calentamiento rápido y alto rendimiento
- Cada placa tiene potencia de 1500W, 1800W con protección contra calor extremo es opcional
- Control de temperatura

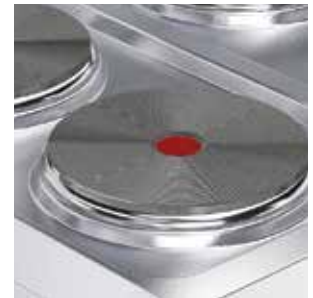

Model	Visual	Dim (mm) LxDxH	Plates kW	Power	Gross Weight	Gross Volume	Electrical Inlet	Price
G6K100E		400x600x300	2x1.5	3 kw	28 kg	0,18 m <sup>3</sup>	230 V 1 N PE	404 €
G6K200E		600x600x300	4x1.5	6 kw	37 Kg	0,28 m <sup>3</sup>	400 V 3 N PE	540 €

# cooking

fryer / friteuse / fritadeira / freidora

# KUSINA®

## 600 SERIES



### General Features

- Stainless steel body
- Easy to clean and hygienic
- Ergonomic design
- Adjustable legs
- Long life
- Adjustable temperature
- Safety Thermostat



### Caractéristiques Générales

- Corps en acier inoxydable
- Facile à nettoyer hygiénique
- Conception ergonomique
- Pieds réglables
- Longue durée
- Température réglable
- Thermostat de sécurité



### Características Gerais

- Corpo de aço inoxidável
- Higiênica, fácil de limpar
- Design económico
- Pés ajustáveis
- Longa durabilidade
- Temperatura de aquecimento ajustável
- Termostato de segurança



### Características Generales

- Estructura de acero inoxidable
- Fácil de limpiar, higiénica
- Diseño ergonómico
- Pies ajustables
- Larga vida útil
- Temperatura ajustable
- Termostato de seguridad



G6F100E



G6F200E



G6F100G

#### PRODCUT HIGHLIGHTING DETAILS

- Single or double containers options
- Stainless steel tube heaters
- Thermostatic heating control
- Stainless steel baskets
- Stainless steel tube heaters
- Operation and heating control indicator lights
- Security switches are easily accessible
- Operating temperature range (0-180 °C)



#### DÉTAILS DU PRODUIT

- Version avec 1 ou 2 bacs
- Contrôle thermostatique de la température
- Paniers en acier inoxydable
- Résistance des tuyaux en acier inoxydable
- Signalisateur de fonctionnement et de la température
- Facile à atteindre au bouton de sécurité
- Plage de température de fonctionnement (0 - 180 °C)

#### DETALHES DO PRODUTO

- Nas versões com compartimento simples ou duplo
- Aquecedores tubulares de aço
- Controle termostático de temperatura
- Cestos inoxidáveis
- Resistência tubular inoxidável
- Luzes indicadoras de acionamento
- Chave de segurança de fácil acesso
- Faixa de temperatura operacional (0 - 180°C)

#### DETALLES DEL PRODUCTO

- Versiones de simple o doble cubetas
- Calentadores con tubos de acero
- Control termostático de la temperatura
- Cestas de acero inoxidable
- Resistencia con tubos de acero inoxidable
- Indicadores de funcionamiento y de la temperatura
- Interruptor de seguridad tiene un acceso fácil
- Rango de la temperatura de funcionamiento (0-180 °C)

Model	Visual	Dim (mm) LxDxH		Power	Gross Weight	Gross Volume	Electrical Inlet	Gas Inlet	Basket Size	Capacity	Price
G6F100E		400x600x300		7,5 kw	23 kg	0,18 m <sup>3</sup>	400 V 3N PE	-	195x265x130	10 lt	824 €
G6F200E		600x600x300		15 kw	35 kg	0,28 m <sup>3</sup>	400 V 3N PE	-	195x265x130	2x10 lt	1.323 €
G6F100G		400x600x300		6 kw	23 kg	0,15 m <sup>3</sup>	-	R ½ "	195x290x90	8 lt	1.091 €

# cooking

pasta cooker / cuisier à pâte / macaroni / cozedor de massas

# KUSINA®

## 600 SERIES



### General Features

- Stainless steel body
- Easy to clean and hygienic
- Safety thermostat
- Stainless steel tube heaters
- Ergonomic design
- Adjustable legs
- Long life



### Caractéristiques Générales

- Corps en acier inoxydable
- Facile à nettoyer hygiénique
- Thermostat de sécurité
- Tuyau du radiateur en acier
- Conception ergonomique
- Pieds réglables
- Longue durée



### Características Gerais

- Corpo de aço inoxidável
- Higiênica, fácil de limpar
- Termostato de segurança
- Aquecedores tubulares de aço
- Design econômico
- Pés ajustáveis
- Longa durabilidade



### Características Generales

- Estructura de acero inoxidable
- Fácil de limpiar, higiénica
- Termostato de seguridad
- Calentadores con tubos de acero inoxidable
- Diseño ergonómico
- Pies ajustables
- Larga vida útil



G6M100E

#### PRODCUT HIGHLIGHTING DETAILS

- Working and safety thermostatic temperature control.
- On - off switch with lights when reaching to the required temperature.
- Operating temperature range (0-120 °C)

#### DÉTAILS DU PRODUIT

- Contrôle de la température de thermostat de fonctionnement et de sécurité
- Interruption automatique une fois la température atteinte
- Dimensions du panier 99x160x135 mm, 4 pièces
- Plage de température de fonctionnement (0 - 120 °C)

#### DETALHES DO PRODUTO

- Controle de funcionamento e segurança termostático
- Luzes indicadoras de liga/desliga ao atingir aquecimento
- Faixa de temperatura operacional (0 - 120°C)

#### DETALLES DEL PRODUCTO

- Control de la temperatura con termostato de funcionamiento y termostato de seguridad
- Luces de apagado - encendido cuando alcanza la temperatura deseada
- Rango de la temperatura de funcionamiento (0-120 °C)

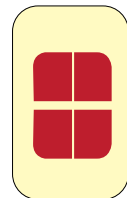

Basket Combination

Model	Visual	Dim (mm) LxDxH		Power	Gross Weight	Gross Volume	Electrical Inlet	Capacity	Basket Size	Price
G6M100E		400x600x300		4,5 kw	17kg	0,18m <sup>3</sup>	400 V 3N PE	10 lt	99x160x135(4pcs)	794 €

# cooking

fry top / grille / churrasqueira / plancha

# KUSINA®

## 600 SERIES



### General Features

- Stainless steel body
- Easy to clean and hygienic
- Safety gas valve
- Ergonomic design
- Adjustable legs
- Long life
- High efficiency burner
- Homogenous cooking surface
- Available LPG or natural gas



### Caractéristiques Générales

- Corps en acier inoxydable
- Facile à nettoyer hygiénique
- Valve à gaz avec soupape de sécurité
- Conception ergonomique
- Pieds réglables
- Longue durée
- Brûleurs à haut rendement
- Surface de cuisson homogène
- Peut fonctionner au GPL et au gaz naturel



### Características Gerais

- Corpo de aço inoxidável
- Higiênica, fácil de limpar
- Válvula de segurança registro de gás
- Design económico
- Pés ajustáveis
- Longa durabilidade
- Queimadores de alta eficiência
- Superfície de cozimento homogêneo
- Funciona com gás natural ou com gás GPL



### Características Generales

- Estructura de acero inoxidable
- Fácil de limpiar, higiénica
- Válvula de gas ,válvula de seguridad
- Diseño ergonómico
- Pies ajustables
- Larga vida útil
- 2 o 4 fuegos abiertos
- Superficie homogénea de cocción
- Puede funcionar con gas natural y GLP



#### PRODCUT HIGHLIGHTING DETAILS

- Smooth, ribbed and ½ smooth + ½ ribbed fry top plates versions
- ST 52 steel or hard chromium coated steel 15 mm thick griddle plate
- Cooking surface perimeter is 3 mm thick stainless steel
- Slightly sloped cooking surface, easy and convenient for cleaning, with liquid discharge hole.
- Homogenous heated cooking surface
- Special machined grooves
- Waste oil drawer
- Thermostatic temperature control
- Thermocouple safety device connected to the burner
- Piezo-electric burner ignition
- Insulation to prevent overheating of the body and reduce energy losses
- Operating temperature range (50-300 ° C)

#### DETALHES DO PRODUTO

- Nas versões com superfície de cozimento plana, com ranhuras ou com ranhuras + plana
- Churrasqueira com 15 mm de espessura aço st 52 ou revestido de cromo duro aço platinum
- Área da superfície de cozimento em aço inoxidável com espessura de 3mm
- Com uma leve inclinação da superfície de cozimento e orifício para escoamento de líquidos proporcionando uma limpeza fácil e confortável
- Superfície de cozimento com aquecimento homogêneo
- Ranhuras com funcionalidades especiais
- Recipiente de óleo residual
- Controle termostático de temperatura
- Sistema de segurança termopar ligado ao queimador
- Queimador de ignição piezoelétrico
- Único ois compartimentos de cozimento independentes
- Isolamento redutor do nível de perda de aquecimento e aquecimento da área das chapas de metal
- Faixa de temperatura operacional (50 -300°C)

#### DÉTAILS DU PRODUIT

- Versions lisse, nervurée et mixte de la surface de cuisson
- Les grilles sont soit en acier ST 52 de 15 mm d'épaisseur soit en acier chromé dur
- Le pourtour de la surface de cuisson est en acier inoxydable et de 3mm d'épaisseur
- Surface de cuisson en pente douce pour le nettoyage facile et pratique, avec un trou de décharge du liquide
- Surface de cuisson facile à chauffer de manière homogène
- Rainures traitées spéciales
- Réservoir d'huile usée
- Contrôle thermostatique de la température
- Système de sécurité à thermocouple lié au brûleur
- Brûleur à l'allumage piézoélectrique
- Une zones de cuisson
- L'isolation de l'appareil prévient les pertes de chaleurs au maximum
- Plage de température de fonctionnement (50 -300 °C)

#### DETALLES DEL PRODUCTO

- Superficie de cocción con versiones de plano, acanalado o o plano + canalado
- Rejillas de acero platina cromadas con cromo duro o acero de st 52 con espesor de 15 mm
- Entorno de la superficie de cocción es de acero inoxidable de 3 mm de espesor
- Superficie de cocción ligeramente inclinada para una limpieza fácil y cómoda con agujero de descarga
- Superficie de cocción que ofrece una cocción homogéneo
- Ranuras procesadas especialmente
- Tanque del aceite usado
- Control termostático de la temperatura
- El sistema de seguridad con termopar conectado al quemador
- Encendido piezoeléctrico del quemador
- Aislamiento que minimiza al calentamiento de las placas en el entorno y minimiza la pérdida de calor
- Rango de la temperatura de funcionamiento (50-300 °C)

# cooking

fry top / grille / churrasqueira / plancha

# KUSINA®

## 600 SERIES

CE



G6I200E



G6I210E



G6I220E



G6I200G



G6I210G



G6I220G



G6I100E



G6I100G



G6I110E



G6I110G

Model	Visual	Dim (mm) LxDxH	Plate Type	Power	Gross Weight	Gross Volume	Gas Inlet	Electrical Inlet	Smooth	Ribbed	Price
G6I200E		600x600x300		6 kw	50 kg	0,28 m³	-	400 V 3N PE	✓		968 €
G6I210E		600x600x300		6 kw	50 kg	0,28 m³	-	400 V 3N PE		✓	1.192 €
G6I220E		600x600x300		6 kw	50 kg	0,28 m³	-	400 V 3N PE	✓	✓	1.102 €
G6I200G		600x600x300		7 kw	50 kg	0,28 m³	R ½ "	-	✓		758 €
G6I210G		600x600x300		7 kw	50 kg	0,28 m³	R ½ "	-		✓	870 €
G6I220G		600x600x300		7 kw	50 kg	0,28 m³	R ½ "	-	✓	✓	851 €
G6I100E		400x600x300		3,6 kw	35 kg	0,18 m³	-	400 V 3N PE	✓		682 €
G6I100G		400x600x300		6 kw	35 kg	0,18 m³	R ½ "	-	✓		614 €
G6I110E		400x600x300		3,6 kw	35 kg	0,18m³	-	400 V 3N PE		✓	851 €
G6I110G		400x600x300		6 kw	37 kg	0,14 m³	R ½ "	-		✓	726 €



# cooking chrome plated

fry top / grille / churrasqueira / plancha

# KUSINA®

## 600 SERIES



G6I200E-C



G6I210E-C



G6I220E-C



G6I200G-C



G6I210G-C



G6I220G-C



G6I100E-C



G6I100G-C



G6I110E-C



G6I110G-C

Model	Visual	Dim (mm) LxDxH	Plate Type	Power	Gross Weight	Gross Volume	Gas Inlet	Electrical Inlet	Smooth	Ribbed	Price
G6I200E-C		600x600x300		6 kw	50 kg	0,28 m³	-	400 V 3N PE	✓		1.332 €
G6I210E-C		600x600x300		6 kw	50 kg	0,28 m³	-	400 V 3N PE		✓	1.556 €
G6I220E-C		600x600x300		6 kw	50 kg	0,28 m³	-	400 V 3N PE	✓	✓	1.466 €
G6I200G-C		600x600x300		7 kw	50 kg	0,28 m³	R ½ "	-	✓		1.122 €
G6I210G-C		600x600x300		7 kw	50 kg	0,28 m³	R ½ "	-		✓	1.234 €
G6I220G-C		600x600x300		7 kw	50 kg	0,28 m³	R ½ "	-	✓	✓	1.215 €
G6I100E-C		400x600x300		3,6 kw	35 kg	0,18 m³	-	400 V 3N PE	✓		934 €
G6I100G-C		400x600x300		6 kw	35 kg	0,18 m³	R ½ "	-	✓		866 €
G6I110E-C		400x600x300		3,6 kw	35 kg	0,18m³	-	400 V 3N PE		✓	1.103 €
G6I110G-C		400x600x300		6 kw	37 kg	0,14 m³	R ½ "	-		✓	978 €

# cooking

chip scuttle / chauffe frite / friet bassin aquecedor de batatas / conservador de patatas

# KUSINA®

## 600 SERIES



### General Features

- Stainless steel body
- Easy to clean and hygienic
- Ergonomic design
- Adjustable legs
- Long life



### Caractéristiques Générales

- Corps en acier inoxydable
- Facile à nettoyer hygiénique
- Conception ergonomique
- Pieds réglables
- Longue durée



### Características Gerais

- Corpo de aço inoxidável
- Higiênica, fácil de limpar
- Design económico
- Pés ajustáveis
- Longa durabilidade



### Características Generales

- Estructura de acero inoxidable
- Fácil de limpiar, higiénica
- Diseño ergonómico
- Pies ajustables
- Larga vida útil



G6D100E

#### PRODCUT HIGHLIGHTING DETAILS

- GN2/3 Container with oil strainer
- The fried potatoes keep warm by custom porcelain infrared heater
- Removable and easy to clean container

#### DÉTAILS DU PRODUIT

- Bac GN 2/3 avec filtre à huile
- La chaleur est fournie par les radiateurs infrarouges en porcelaine spéciale
- Reservoir du chauffe frite amovible et facile à nettoyer

#### DETALHES DO PRODUTO

- Compartmento de batatas GN 2/3 com filtro para óleo
- Com o aquecimento infravermelho por porcelana especial mantém a temperatura das batatas fritas
- Compartmento de batatas removível e de fácil limpeza

#### DETALLES DEL PRODUCTO

- Cubeta para conservar patatas de G/N 2/3 con filtro de aceite
- Mantiene caliente a las patatas fritas mediante los calentadores infrarrojos de porcelana especial
- Cubeta desmontable y fácil de limpiar para conservar patatas



Model	Visual	Dim (mm) LxDxH		Power	Gross Weight	Gross Volume	Electrical Inlet	Price
G6D100E		400x600x300		0,85 kw	20 kg	0,18 m <sup>3</sup>	230 V N PE	404 €

# cooking

sauce bain marie / bain-marie pour sauce /  
banho-maria para molhos / baño maria

# KUSINA®

## 600 SERIES



### General Features

- Stainless steel body
- Easy to clean and hygienic
- Ergonomic design
- Adjustable legs
- Long life
- Safety Thermostat



### Caractéristiques Générales

- Corps en acier inoxydable
- Facile à nettoyer hygiénique
- Conception ergonomique
- Pieds réglables
- Longue durée
- Thermostat de sécurité



### Características Gerais

- Corpo de aço inoxidável
- Higiênica, fácil de limpar
- Design econômico
- Pés ajustáveis
- Longa durabilidade
- Termostato de segurança



### Características Generales

- Estructura de acero inoxidable
- Fácil de limpiar, higiénica
- Diseño ergonómico
- Pies ajustables
- Larga vida útil
- Termostato de seguridad



G6S100E

#### PRODUCT HIGHLIGHTING DETAILS

- Emergency valve for emptying
- ½ Gn Container -Hot
- 1/6 Warm sauce Preservation , 2 pcs 1/6
- Neutral 2 Pcs 1/6 GN sauce containers
- Operating temperature range (30-90 °C)

#### DÉTAILS DU PRODUIT

- Soupape de sécurité pour évacuer la chaleur du GN ½
- 2 bacs GN 1/6 conservation de sauce neutre
- 2 bacs GN 1/6 pour la conservation de sauce non chauffée
- Plage de température de fonctionnement (30-90 °C)

#### DETALHES DO PRODUTO

- Válvula de segurança quente ½ GN
- 2 unidades de 1/6 GN gabinete para molhos - neutro
- Para gabinetes de molhos não aquecidos 2 unidades de 1/6 GN
- Faixa de temperatura operacional (30 -90°C)

#### DETALLES DEL PRODUCTO

- Válvula de seguridad en caliente GN ½
- 2 Mantenedores de salsa de GN 1/6 - neutro
- 2 Mantenedores de salsa de GN 1/6 sin calentamiento
- Rango de la temperatura de funcionamiento (30-90 °C)



Model	Visual	Dim (mm) LxDxH		Power	Gross Weight	Gross Volume	Electrical Inlet	Tank Capacity	Price
G6S100E		400x600x300		1,5 kw	21 kg	0,18 m³	230 V 1 N PE	GN 1/2 150 mm x1 GN 1/6 150 mm x2	491 €

# cooking

lavastone griddle / grille de pierre de lave /  
churrasqueira de obsidiana / plancha con piedra volcánica

# KUSINA®

## 600 SERIES



### General Features

- Stainless steel body
- Easy to clean and hygienic
- Ergonomic design
- Adjustable legs
- Long life



### Caractéristiques Générales

- Corps en acier inoxydable
- Facile à nettoyer hygiénique
- Valve à gaz avec soupape de sécurité
- Conception ergonomique
- Pieds réglables
- Longue durée



### Características Gerais

- Corpo de aço inoxidável
- Higiênica, fácil de limpar
- Válvula de segurança registro de gás
- Design econômico
- Pés ajustáveis
- Longa durabilidade



### Características Generales

- Estructura de acero inoxidable
- Fácil de limpiar, higiénica
- Válvula de gas, válvula de seguridad
- Diseño ergonómico
- Pies ajustables
- Larga vida útil



G6L200G

#### PRODCUT HIGHLIGHTING DETAILS

- Long life Cast iron griddle under the lavstones
- Homogenous cooking surface
- Stainless steel V-shape grilling grate
- Waste oil drawer
- Piezo-electric burner ignition
- Independent two cooking areas of surface insulation to prevent overheating of the body and reduce energy losses
- Slightly sloped cooking surface, easy and convenient for cleaning, with liquid discharge hole.

#### DÉTAILS DU PRODUIT

- Grille inférieure de pierre de lave de longue durée en fonte
- Surface de cuisson homogène
- Grille en acier sous forme "V"
- Réservoir d'huile usée
- Brûleur à l'allumage piezoelectrique
- Une zones de cuissons
- L'isolation de l'appareil prévient les pertes de chaleur au maximum
- Surface de cuisson en pente douce pour un nettoyage facile et pratique, avec trou de décharge de liquide



#### DETALLES DEL PRODUCTO

- Rejilla inferior de piedra volcánica hecha de hierro fundido con larga vida útil
- Superficie homogénea de cocción
- Rejilla de de cocción de acero en forma "V"
- Tanque del aceite usado
- Encendido piezoeléctrico del quemador
- Aislamiento que minimiza al calentamiento de las placas en el entorno y minimiza la pérdida de calor
- Superficie de cocción ligeramente inclinada para una limpieza fácil y cómoda con agujero de descarga

#### DETALHES DO PRODUTO

- Grelha inferior feita em ferro fundido obsidiana de longa durabilidade
- Superfície de cozimento homogêneo
- Grelha de aço em forma de "V"
- Recipiente de óleo residual
- Queimador de ignição piezoelétrico
- Único compartimentos de cozimento independentes
- Isolamento redutor do nível de perda de aquecimento e aquecimento da área das chapas de metal
- Com uma leve inclinação da superfície de cozimento e orifício para escoamento de líquidos proporcionando uma limpeza fácil e confortável

Model	Visual	Dim (mm) LxDxH		Power	Gross Weight	Gross Volume	Gas Inlet	Price
G6L200G		600x600x300		8 kw	41 kg	0,28 m <sup>3</sup>	R1/2"	936 €

# cooking

neutral unit / élément intermédiaire /  
bancada para descanso / mesa de soporte

# KUSINA

## 600 SERIES

CE



### General Features

- Stainless steel body
- Easy to clean and hygienic
- Ergonomic design
- Adjustable legs
- Long life



### Caractéristiques Générales

- Corps en acier inoxydable
- Facile à nettoyer hygiénique
- Conception ergonomique
- Pieds réglables
- Longue durée



### Características Gerais

- Corpo de aço inoxidável
- Higiênica, fácil de limpar
- Design económico
- Pés ajustáveis
- Longa durabilidade



### Características Generales

- Estructura de acero inoxidable
- Fácil de limpiar, higiénica
- Diseño ergonómico
- Pies ajustables
- Larga vida útil



G6T100N



G6T200N



#### PRODCUT HIGHLIGHTING DETAILS

- Unscratchable and enamelde cast iron back grate

#### DÉTAILS DU PRODUIT

- Cheminee en fonte émaillée, inoxydable et anti-rayures

#### DETALHES DO PRODUTO

- Chaminé de ferro fundido esmaltado à prova de riscos

#### DETALLES DEL PRODUCTO

- Chimenea de hierro fundido esmaltado inoxidable y no se raya



Model	Visual	Dim (mm) LxDxH		Gross Weight	Gross Volume	Price
G6T100N		400x600x300		14 kg	0,18 m <sup>3</sup>	219 €
G6T200N		600x600x300		17 kg	0,28 m <sup>3</sup>	251 €



### General Features

- Stainless steel body
- Easy to clean and hygienic
- Ergonomic design
- Adjustable legs
- Long life



### Caractéristiques Générales

- Corps en acier inoxydable
- Facile à nettoyer hygiénique
- Conception ergonomique
- Pieds réglables
- Longue durée



### Características Gerais

- Corpo de aço inoxidável
- Higiênica, fácil de limpar
- Design econômico
- Pés ajustáveis
- Longa durabilidade



### Características Generales

- Estructura de acero inoxidable
- Fácil de limpiar, higiénica
- Diseño ergonómico
- Pies ajustables
- Larga vida útil



G6ST100



G6ST200

Model	Visual	Dim (mm) LxDxH		Gross Weight	Gross Volume	Price
G6ST100		400x600x600		14 kg	0,18 m <sup>3</sup>	230 €
G6ST200		600x600x600		19 kg	0,28 m <sup>3</sup>	259 €



***KUSINA***<sup>®</sup>



**700 SERIES**



# cooking

gas range / cuisinière à gaz / fogão à gás /  
cocina a gas

# KUSINA®

## 700 SERIES



### General Features

- Stainless steel body
- Easy to clean and hygienic
- Safety gas valve
- Ergonomic design
- Adjustable legs
- Long life
- High efficiency burner
- Isolated oven



### Caractéristiques Générales

- Corps en acier inoxydable
- Facile à nettoyer hygiénique
- Valve à gaz de soupape de sécurité
- Conception ergonomique
- Pieds réglables
- Longue durée
- Brûleurs à haut rendement
- Four avec isolation



### Características Gerais

- Corpo de aço inoxidável
- Higiênica, fácil de limpar
- Válvula de segurança registro de gás
- Design econômico
- Pés ajustáveis
- Longa durabilidade
- Queimadores de alta eficiência
- Forno com isolamento



### Características Generales

- Estructura de acero inoxidable
- Fácil de limpiar, higiénica
- Válvula de gas ,válvula de seguridad
- Diseño ergonómico
- Pies ajustables
- Larga vida útil
- 2 o 4 fuegos abiertos
- Horno aislado

#### PRODCUT HIGHLIGHTING DETAILS

- 2/4 and 6 Burners , with or without oven
- Easy to clean and simple maintenance with removable Burner Bottom Tray
- Unscratchable and enameled cast iron top grates.
- Nickel coated cast iron burners
- Protected Pilot Flame
- With oven or cupboards
- Oven available for 2/1 GN trays
- Enamel coated bottom steel sheet
- The body of the oven is made of aluminium coated sheet metal
- Stainless steel double-wall insulated door
- Self stabilizing flame
- Removable and easy to clean stainless steel oven shelves
- Thermostatic temperature control with safety valve and thermocouple
- Piezo-electric burner ignition

#### DETALHES DO PRODUTO

- 2,4 e 6 queimadores, fácil limpeza e manutenção proporcionadas pelo queimador e bandeja inferior removíveis
- Chaminé e grelha do fogão de ferro fundido esmaltado à prova de riscos de fácil limpeza
- bocas de ferro fundido niquelado
- Chama-piloto protegido
- Com forno ou com gabinete inferior
- medida GN 2/1 apropriada para o interior do forno
- Chapa do fundo do forno esmaltada
- chapa do corpo do forno feita de alumínio
- Porta isolante com parede dupla feita de aço inoxidável
- estabilizador de chama
- Prateleiras do forno em aço inoxidável removíveis de fácil limpeza
- Temperatura ajustável válvula de segurança e registro de gás
- Forno com acendimento piezoelétrico
- 2, 4 e 6 queimadores (bocas), modelos com e sem forno
- Forno com prateleiras em aço inoxidável removíveis de fácil limpeza

#### DÉTAILS DU PRODUIT

- 2, 4 et 6 brûleurs , plateau inférieur du brûleur amovible, permettant un nettoyage facile, l'entretien et la réparation
- Cheminée et grille supérieure émaillée, en fonte,anti-rayures,facile à nettoyer.
- Les fours sont en fonte nickelée. Lampe-témoin protégée.
- Fourneau ou armoire inférieur- l'intérieur du fourneau est conforme à la dimension GN 2/1- la tôle du plancher du four est en acier émaillé- corps du four
- Fabriqué en tôle revetue d'aluminium
- La porte est en acier inoxydable, isolée à double membranes avec lampe témoin stabilisée, les grilles sont en acier inoxydables amovibles et faciles à nettoyer
- Robinet à gaz avec vanne thermostatique de sécurité de réglage de la température- veilleuse du four de l'allumage piézoélectrique

#### DETALLES DEL PRODUCTO

- Recipiente inferior extraible de quemador con 2.4 y 6 fuegos abiertos, facil que limpieza, mantenimiento y reparación
- Chimenea y rejilla superior de hierro fundido con recubrimiento de esmalte que se puede limpiar fácilmente y no se raya
- Quemadores niquelados de hierro fundido
- Llama piloto con protección
- Con horno o armario inferior
- Dimenisiones interiores del horno están de acuerdo con GN 2/1
- Placa de fondo de hierro esmaltado del horno
- Estructura de horno hecho de placa recubierta con aluminio
- Puerta aislada de doble pared de acero inoxidable
- Llama estabilizada de la luz piloto del horno
- Estantes de horno de acero inoxidable que son extraíbles y fáciles de limpiar
- Válvula termostático de gas con válvula de seguridad, temperatura ajustable
- Encendedor de horno con piloto piezoelétrico.
- Modelos con/sin horno con 2,4 y 6 fuegos abiertos
- Estantes del horno de acero inoxidable que son extraíbles y fáciles de limpiar



# cooking

gas range / cuisinière à gaz / fogão à gás / cocina a gas

# KUSINA®

## 700 SERIES

CE



G7K100G



G7K200G



G7K201G



G7K210G



G7K211G



G7K212G



020.02.04.250



020.03.10.052



020.03.10.056



7RC100G  
reduction

Model	Visual	Dim (mm) LxDxH	Burners kW	Power	Gross Weight	Gross Volume	Gas Inlet	Tray Dimensions	Oven kW	Price
G7K100G		400x730x900	2x6.5	13 kw	52 kg	0,46 m <sup>3</sup>	R ½ "	-	-	933 €
G7K200G		800x730x900	4x6.5	26 kw	95 kg	0,90 m <sup>3</sup>	R ½ "	-	-	1.421 €
G7K201G		1200x730x900	6x6.5	39 kw	145 kg	1,22 m <sup>3</sup>	R ½ "	-	-	1.743 €
G7K210G		800x730x900	4x6,5	32 kw	135 kg	0,84 m <sup>3</sup>	R ½ "	GN 2/1x2	6	2.067 €
G7K211G		1200x730x900	6x6.5	45 kw	203 kg	1,60 m <sup>3</sup>	R ½ "	GN 2/1x2	6	2.620 €
G7K212G		1200x730x900	6x6.5	49 kw	206 kg	1,60 m <sup>3</sup>	R ½ "	-	10	3.209 €

# cooking

electrical range / cuisinière électrique / fogão elétrico / cocina eléctrica

# KUSINA®

## 700 SERIES



### General Features

- Stainless steel body
- Easy to clean and hygienic
- Ergonomic design
- Adjustable legs
- Long life
- Insulated oven



### Caractéristiques Générales

- Corps en acier inoxydable
- Facile à nettoyer hygiénique
- Conception ergonomique
- Pieds réglables
- Longue durée
- Four avec isolation



### Características Gerais

- Corpo de aço inoxidável
- Higiénica, fácil de limpar
- Válvula de segurança registro de gás
- Design económico
- Pés ajustáveis
- Longa durabilidade
- Forno com isolamento



### Características Generales

- Estructura de acero inoxidable
- Fácil de limpiar, higiénica
- Diseño ergonómico
- Pies ajustables
- Larga vida útil
- Horno aislado



G7K100E



G7K200E



G7K210E

#### PRODUCT HIGHLIGHTING DETAILS

- 2 or 4 heating plates, with or without oven models
- Ø 180 mm and Ø 230 mm - two types of cooking plates
- Unscratchable enameled cast iron back grate
- With oven or cupboards
- Oven available for 2/1 GN trays
- Enamel coated bottom steel sheet
- The body of the oven is made of aluminium coated sheet metal
- Stainless steel double-wall, insulated door
- Stainless steel tube heaters
- Adjustable thermostatic temperature control
- Indicator lights when reaching to the required temperature

#### DÉTAILS DU PRODUIT

- Modèles de 2 et 4 plaques chauffantes, avec four ou sans four
- 2 type de plaques de cuisson de Ø 180 et 230 mm
- Cheminée en fonte émaillée inoxydable et anti-rayures
- Fourneau ou armoire inférieur- l'intérieur du fourneau est conforme à la dimension GN 2/1- la tôle du plancher du four est en acier émaillé
- Signal optique on-off à l'atteint de la température désirée- corps du four en tôle revêue d'aluminium
- La porte en acier inoxydable isolée à double membranes - Chauffe-tuyau inoxydable
- Contrôle de la température du thermostat réglable



#### DETALHES DO PRODUTO

- Com 2 ou 4 placas de aquecimento, modelos com ou sem forno
- Dois tipos de placa com aproximadamente Ø 180 e Ø 230 mm
- Chaminé de ferro fundido esmaltado à prova de riscos
- Com forno ou com gabinete inferior
- medida GN 2/1 apropriada para o interior do forno
- Chapa do fundo do forno esmaltada
- Luzes de aviso liga/desliga ao atingir a temperatura desejada
- corpo do forno feito de chapa revestida de alumínio
- Porta isolante com parede dupla feita de aço inoxidável
- Resistência cilíndrica inoxidável
- Controle ajustável de temperatura termostático
- Luzes de aviso ao atingir a temperatura desejada

#### DETALLES DEL PRODUCTO

- Modelos con 2,4 placas calientes, con/sin horno
- Dos tipos de placas calientes de Ø 180 y Ø 230 mm
- Chimenea de hierro fundido esmaltado que es inoxidable y no se raya
- Con horno o armario inferior
- Dimensiones interiores del horno están de acuerdo con GN 2/1
- Placa de fondo de hierro esmaltado del horno
- Luces de apagado - encendido cuando alcanza la temperatura deseada
- Estructura de horno hecho de placa recubierta con aluminio
- Puerta aislada de doble pared de acero inoxidable
- Calentadores de tubos de acero inoxidable
- Control termostático con temperatura ajustable
- Luces de advertencia cuando se alcanza la temperatura deseada

Model	Visual	Dim (mm) LxDxH	Plates kW	Gross Weight	Gross Volume	Volume	Electrical Inlet	Tray Dimensions	Price
G7K100E		400x730x900	1x1,5 1x2	3,5 kw	45 kg	0,46 m <sup>3</sup>	230 V 1N PE	-	720 €
G7K200E		800x730x900	2x1,5 2x2	7 kw	130 kg	0,84 m <sup>3</sup>	400 V 3N PE	-	1.110 €
G7K210E		800x730x900	2x1,5 2x2 Oven 6	13 kw	140 kg	0,84 m <sup>3</sup>	400 V 3N PE	GN 2/1x2	1.882 €

# cooking

pasta cooker / cuiseur à pâte / macaroni / cozedor de massas / cocedor de pasta

# KUSINA®

## 700 SERIES



### General Features

- Stainless steel body
- Easy to clean and hygienic
- Safety Thermostat
- Ergonomic design
- Adjustable legs
- Long life
- Single or double cooking containers



### Caractéristiques Générales

- Corps en acier inoxydable
- Facile à nettoyer hygiénique
- Thermostat de sécurité
- Conception ergonomique
- Pieds réglables
- Longue durée
- 1 et 2 bacs



### Características Gerais

- Corpo de aço inoxidável
- Higiênica, fácil de limpar
- Termostato de segurança
- Design econômico
- Pés ajustáveis
- Longa durabilidade
- Compartimento Simples ou Duplo



### Características Generales

- Estructura de acero inoxidable
- Fácil de limpiar, higiénica
- Termostato de seguridad
- Diseño ergonómico
- Pies ajustables
- Larga vida útil
- Cubierta Simple y Doble



G7M100E



G7M100G



G7M200E

#### PRODCUT HIGHLIGHTING DETAILS

- Working and safety thermostatic temperature control
- On-off switch with lights when reaching to the required temperature.
- Cooking container with overflow drain
- Stainless steel tube heaters
- Indicator lights when reaching to the required temperature
- Operating temperature range (0-120 °C)

#### DÉTAILS DU PRODUIT

- Contrôle de la température du thermostat de fonctionnement et de sécurité
- Lumière de on-off à l'atteint de la température
- Bac de trop-plein lié au tuyau d'évacuation
- Chauffage de tube en acier inoxydable
- Plage de température de fonctionnement (0-120 °C)

#### DETALHES DO PRODUTO

- Controle de funcionamento e segurança termostático
- Luzes indicadoras de liga/desliga ao atingir aquecimento
- Compartimento com escoamento
- Aquecedor tubular de aço inoxidável
- Faixa de temperatura operacional (0 -120°C)

#### DETALLES DEL PRODUCTO

- Control de la temperatura con termostato de funcionamiento y termostato de seguridad
- Luces de apagado - encendido cuando alcanza la temperatura deseada
- Cubeta con desagüe con rebosadero de desagüe
- Calentador de tubo de acero inoxidable
- Rango de la temperatura de funcionamiento (0-120 °C)



Basket Combination

Model	Visual	Dim (mm) LxDxH		Power	Gross Weight	Gross Volume	Electrical Inlet	Gas Inlet	Capacity	Basket Size	Price
G7M100E		400x730x900		10 kw	52 kg	0,44 m³	400 V 3N PE	-	22 lt	135x180x180 (2pcs) 145x270x180 (1pcs)	1.252 €
G7M100G		400x730x900		8 kw	74 kg	0,46 m³	-	R ½"	22 lt	190x237x255 (1pcs) 115x190x255 (2pcs)	1.233 €
G7M200E		800x730x900		20 kw	110 kg	0,84 m³	400 V 3N PE	-	2x22 lt	135x180x180 (4pcs) 145x270x180 (2pcs)	1.860 €

# cooking

fry top / grille / churrasqueira / plancha

# KUSINA®

## 700 SERIES



### General Features

- Stainless steel body
- Easy to clean and hygienic
- Safety gas valve
- Ergonomic design
- Adjustable legs
- Long life
- High efficiency burner
- Available lpg or natural gas



### Caractéristiques Générales

- Corps en acier inoxydable
- Facile à nettoyer hygiénique
- Valve à gaz avec soupape de sécurité
- Conception ergonomique
- Pieds réglables
- Longue durée
- Brûleurs à haut rendement
- Peut fonctionner au GPL et au gaz naturel



### Características Gerais

- Corpo de aço inoxidável
- Higiênica, fácil de limpar
- Válvula de segurança registro de gás
- Design económico
- Pés ajustáveis
- Longa durabilidade
- Queimadores de alta eficiência
- Funciona com gás natural ou com gás GPL



### Características Generales

- Estructura de acero inoxidable
- Fácil de limpiar, higiénica
- Válvula de gas ,válvula de seguridad
- Diseño ergonómico
- Pies ajustables
- Larga vida útil
- Puede funcionar con gas natural y GLP

#### PRODUCT HIGHLIGHTING DETAILS

- Smooth, ribbed and ½ smooth + ½ ribbed fry top plates versions
- Fry top with cupboard
- ST 52 steel or hard chromium coated steel 15 mm thick griddle plate
- Cooking surface perimeter is 3 mm thick stainless steel
- Stainless Steel Oil collection drawer is placed in cupboard
- Slightly sloped cooking surface , easy and convenient for cleaning, with liquid discharge hole.
- Homogenous heated cooking surface
- Special machined grooves
- Waste oil drawer
- Thermostatic temperature control
- Thermocouple safety device connected to the burner
- Piezo-electric burner ignition
- Double independent cooking surface
- Insulation to prevent overheating of the body and reduce energy losses
- Operating temperature range (50-300 ° C)

#### DETALHES DO PRODUTO

- Nas versões com superfície de cozimento plana, com ranhuras ou com ranhuras + plana
- Churrasqueira com gabinete inferior com portas
  - Churrasqueira com 15 mm de espessura aço st 52 ou revestido de cromo duro aço platinum
  - Área da superfície de cozimento em aço inoxidável com espessura de 3mm
  - Gaveta coletora de gordura em aço inoxidável localizada dentro do gabinete
  - Superfície de cozimento com uma leve inclinação para uma limpeza fácil e confortável
  - Orifício para escoamento de líquidos • superfície de cozimento com aquecimento homogêneo
  - Ranhuras com funcionalidades especiais • Recipiente de óleo residual
  - Controle termostático de temperatura
  - Sistema de segurança termopar ligado ao queimador
  - Queimadores com acionamento piezoelétrico nas versões com uma ou duas áreas de cozimento independentes
  - Isolamento redutor do nível de perda de aquecimento e aquecimento da área das chapas de metal
  - Queimadores com acionamento piezoelétrico duas áreas de cozimento independentes
  - Isolamento redutor do nível de perda de aquecimento e aquecimento da área das chapas de metal
  - Orifício para escoamento de líquidos
  - Isolamento redutor do aquecimento da área das chapas e perda de temperatura
  - Faixa de temperatura operacional (50-300°C)

#### DÉTAILS DU PRODUIT

- Versions lisse, nervurée et mixte de la surface de cuisson
- Armoires avec portes sous le grille
- Les grilles sont soit en acier ST 52 de 15 mm d'épaisseur soit en acier et chromé dur
- Le pourtour de surface de cuisson est en acier inoxydable de 3mm d'épaisseur
- Tiroir de récupération des graisses en acier inoxydable placé à l'intérieur du placard
- Surface de cuisson en pente douce pour le nettoyage facile et pratique
- Trou de décharge du liquide- surface de cuisson avec chauffer homogène
- Rainures avec traitement spécial- Réservoir d'huile usée
- Contrôle de la température thermostatique
- Un système de sécurité à thermocouple est lié au brûleur
- Brûleur à l'allumage piézoélectrique avec versions à une ou deux zones de cuissons indépendantes
- L'isolation de l'appareil prévient la perte de chaleur au maximum
- Brûleur à l'allumage piézoélectrique à deux zones de cuissons indépendantes
- Plage de température de fonctionnement (50-300 °C)

#### DETALLES DEL PRODUCTO

- Versiones de la superficie de cocción son plana, acanalada o acanalada
- Armario con puertas en la parte inferior de la plancha
- Rejillas de acero platina cromadas con cromo duro o acero de st 52 con espesor de 15 mm
- Entorno de la superficie de cocción es de acero inoxidable de 3 mm de espesor
- Cajón de recogida de grasas de acero inoxidable colocado dentro del armario
- Superficie de cocción ligeramente inclinada para una limpieza fácil y cómoda
- Orificio de drenaje de líquido
- Superficie de cocción que ofrece una cocción homogéneo
- Ranuras procesadas especialmente
- Tanque del aceite usado
- Control termostático de la temperatura
- El sistema de seguridad con termopar conectado al quemador
- Versiones de zonas de cocción con una o dos zonas independientes y con quemados de encendido piezoeléctrico
- Aislamiento que minimiza al calentamiento de las placas en el entorno y minimiza la pérdida de calor
- Dos zonas de cocción con quemados de encendido piezoeléctrico
- Aislamiento que minimiza al calentamiento de las placas en el entorno y minimiza la pérdida de calor
- Orificio de drenaje de líquido
- Aislamiento que minimiza al calentamiento de las placas en el entorno y minimiza la pérdida de calor
- Rango de la temperatura de funcionamiento (30-90 °C)



# cooking

fry top/ grille / churrasqueira/ plancha

# KUSINA®

## 700 SERIES

CE



G7I200E



G7I210E



G7I220E



G7I200G



G7I210G



G7I220G



G7I100E



G7I110E



G7I100G



G7I110G

Model	Visual	Dim (mm) LxDxH	Plate Type	Power	Gross Weight	Gross Volume	Gas Inlet	Electrical Inlet	Smooth	Ribbed	Price
G7I200E		800x730x900		7,2 kw	140 kg	0,84 m <sup>3</sup>	-	400 V 3N PE	✓		1.459 €
G7I210E		800x730x900		7,2 kw	140 kg	0,95 m <sup>3</sup>	-	400 V 3N PE		✓	1.783 €
G7I220E		800x730x900		7,2 kw	140 kg	0,84 m <sup>3</sup>	-	400 V 3N PE	✓	✓	1.560 €
G7I200G		800x730x900		13 kw	126 kg	0,84 m <sup>3</sup>	R ½ "	-	✓		1.328 €
G7I210G		800x730x900		13 kw	126 kg	0,90 m <sup>3</sup>	R ½ "	-		✓	1.740 €
G7I220G		800x730x900		13 kw	126 kg	0,90 m <sup>3</sup>	R ½ "	-	✓	✓	1.511 €
G7I100E		400x730x900		3,6 kw	95 kg	0,45 m <sup>3</sup>	-	400 V 3N PE	✓		949 €
G7I110E		400x730x900		3,6 kw	95 kg	0,45 m <sup>3</sup>	-	400 V 3N PE	-	✓	1.173 €
G7I100G		400x730x900		6,5 kw	83 kg	0,45 m <sup>3</sup>	R ½ "	-	✓	-	914 €
G7I110G		400x730x900		6,5 kw	95 kg	0,45 m <sup>3</sup>	R ½ "	-		✓	1.162 €

# cooking chrome plated

fry top / grille / churrasqueira / plancha

# KUSINA®

## 700 SERIES

CE



G7I200E-C



G7I210E-C



G7I220E-C



G7I200G-C



G7I210G-C



G7I220G-C



G7I100E-C



G7I110E-C



G7I100G-C



G7I110G-C

Model	Visual	Dim (mm) LxDxH	Plate Type	Power	Gross Weight	Gross Volume	Gas Inlet	Electrical Inlet	Smooth	Ribbed	Price
G7I200E-C		800x730x900		7,2 kw	140 kg	0,84 m <sup>3</sup>	-	400 V 3N PE	✓		1.938 €
G7I210E-C		800x730x900		7,2 kw	140 kg	0,95 m <sup>3</sup>	-	400 V 3N PE		✓	2.262 €
G7I220E-C		800x730x900		7,2 kw	140 kg	0,84 m <sup>3</sup>	-	400 V 3N PE	✓	✓	2.039 €
G7I200G-C		800x730x900		13 kw	126 kg	0,84 m <sup>3</sup>	R ½ "	-	✓		1.807 €
G7I210G-C		800x730x900		13 kw	126 kg	0,90 m <sup>3</sup>	R ½ "	-		✓	2.219 €
G7I220G-C		800x730x900		13 kw	126 kg	0,90 m <sup>3</sup>	R ½ "	-	✓	✓	1.990 €
G7I100E-C		400x730x900		3,6 kw	95 kg	0,45 m <sup>3</sup>	-	400 V 3N PE	✓		1.218 €
G7I110E-C		400x730x900		3,6 kw	95 kg	0,45 m <sup>3</sup>	-	400 V 3N PE		✓	1.442 €
G7I100G-C		400x730x900		6,5 kw	83 kg	0,45 m <sup>3</sup>	R ½ "	-	✓		1.183 €
G7I110G-C		400x730x900		6,5 kw	95 kg	0,45 m <sup>3</sup>	R ½ "	-		✓	1.431 €

# cooking

fryer / friteuse / fritadeira / freidora

# KUSINA®

## 700 SERIES



### General Features

- Stainless steel body
- Easy to clean and hygienic
- Safety gas valve
- Ergonomic design
- Adjustable legs
- Long life
- High efficiency burner
- Homogenous cooking surface
- Available lpg or natural gas



### Caractéristiques Générales

- Corps en acier inoxydable
- Facile à nettoyer hygiénique
- Conception ergonomique
- Pieds réglables
- Longue durée
- Corps monobloc
- Valve à gaz avec sopapae de sécurité
- Thermostat de sécurité
- Différentes capacités sont disponibles



### Características Gerais

- Corpo de aço inoxidável
- Higiênica, fácil de limpar
- Design econômico
- Pés ajustáveis
- Longa durabilidade
- Corpo monobloco
- Válvula de segurança registro de gás
- Termostato de segurança



### Características Generales

- Estructura de acero inoxidable
- Fácil de limpiar, higiénica
- Diseño ergonómico
- Pies ajustables
- Larga vida útil
- Estructura monobloque
- Válvula de gas ,válvula de seguridad
- Termostato de seguridad

### PRODCUT HIGHLIGHTING DETAILS

- Single or double container models
- Unscratchable and stainless enameled cast back grate
- Fryer with cupboard
- Piezo-electric burner ignition
- Thermostatic temperature control
- Stainless steel baskets
- Adjustable temperature
- High efficient gas combustion system
- Operation and heating control indicator lights
- Stainless steel tube heaters
- Operating temperature range (0-180 ° C)

### DÉTAILS DU PRODUIT

- Modèles avec 1 ou 2 bacs
- Cheminée en fonte émaillé inoxydable et anti-rayures
- Armoire inférieure avec porte
- Brûleur à l'allumage piézoélectrique
- Contrôle de la température du thermostat
- Paniers en acier inoxydable
- Température réglable
- Système de combustion de gaz à grande efficacité
- Indicateurs de fonctionnement et de température
- Résistance de tuyau inoxydable
- Plage de température de fonctionnement (0-180 ° C)

### DETALHES DO PRODUTO

- Nas versões com compartimento simples ou duplo
- Chaminé de ferro fundido esmaltado à prova de riscos
- Gabinete inferior com portas
- Queimador de ignição piezoelétrico
- Controle de temperatura termostático
- Cestos inoxidáveis
- Temperatura de aquecimento ajustável
- Sistema de combustão à gás que proporciona alta eficiência
- Luzes indicadoras de acionamento
- Resistência tubular inoxidável
- Faixa de temperatura operacional (0 -180°C)

### DETALLES DEL PRODUCTO

- Versiones de simple o doble cubetas
- Chimenea de hierro fundido esmaltado inoxidable y no se raya
- Armario inferior con puertas
- Encendido piezoeléctrico del quemador
- Control termostático de temperatura
- Cestas inoxidables
- Temperatura ajustable
- Sistema de quema de gas de alta eficiencia
- Indicadores de funcionamiento y de la temperatura
- Resistencia con tubos de acero inoxidable
- Rango de la temperatura de funcionamiento (0-180 ° C)



G7F100E



G7F200E



G7F100G



G7F200G



Model	Visual	Dim (mm) LxDxH		Power	Gross Weight	Gross Volume	Gas Inlet	Electrical Inlet	Basket Size	Capacity	Price
G7F100E		400x730x900		15 kw	55 kg	0,44 m <sup>3</sup>	-	400 V 3N PE	140x280x170	20 lt	1.227 €
G7F200E		800x730x900		30 kw	86 kg	0,84 m <sup>3</sup>	-	400 V 3N PE	140x280x170	2x 20 lt	1.991 €
G7F100G		400x730x900		15 kw	64 kg	0,45 m <sup>3</sup>	R ½ "	-	140x280x130	15 lt	1.456 €
G7F200G		800x730x900		30 kw	87 kg	0,84 m <sup>3</sup>	R ½ "	-	140x280x130	2x15 lt	2,394 €



# cooking

tilting bratt pan / sauteuse basculante / frigideira basculante / sartén basculante

# KUSINA®

## 700 SERIES



### General Features

- Stainless steel body
- Easy to clean and hygienic
- Ergonomic design
- Adjustable legs
- Long life



### Caractéristiques Générales

- Corps en acier inoxydable
- Facile à nettoyer hygiénique
- Conception ergonomique
- Pieds réglables
- Longue durée



### Características Gerais

- Corpo de aço inoxidável
- Higiênica, fácil de limpar
- Design econômico
- Pés ajustáveis
- Longa durabilidade



### Características Generales

- Estructura de acero inoxidable
- Fácil de limpiar, higiénica
- Diseño ergonómico
- Pies ajustables
- Larga vida útil



G7TD200E



G7TD200G



#### PRODUCT HIGHLIGHTING DETAILS

- Stainless steel cooking pan
- While tilting bratt pan switch step in, system stops
- Safety thermostat
- Pilot light and valve with thermocouple
- Piezo-electric burner ignition
- Water filling pipe controlled from front panel
- Self hinged lid
- 200 mm depth stainless steel pan
- Unscratchable enameled cast iron back grate
- Thermostatic temperature control
- Tubular burner placed under the tank
- Adjustable heating system 50°C - 300°C
- Hand-wheel boost system



#### DÉTAILS DU PRODUIT

- Chaudière inoxydable
- Interrupteur de sécurité arrêt de travail avec le retrait de chaudière
- Thermostat de sécurité
- Lampe-témoin et valve à thermocouple
- Brûleur à l'allumage piézoélectrique
- Chargeur d'eau contrôlé par le panneau avant
- Cuve en acier inoxydable pivotante sur soi avec profondeur de la cuve de 200 mm
- Cheminée en fonte émaillée inoxydable et anti-rayures
- Contrôle de la température du thermostat
- Tuyaux de chauffe inoxydables sous la cuve de cuisson
- Température réglable de 50°C - 300°C
- Signal optique à l'atteinte de la température désirée
- Volant manuel

#### DETALHES DO PRODUTO

- Caldeira inoxidável
- Botão de segurança para interrupção de funcionamento quando a caldeira é removida
- Termostato de segurança.
- Chama piloto e válvula termopar (chama que apaga)
- Queimador de acionamento piezoelétrico
- Tubo de enchimento de água, controlado a partir de painel frontal
- Tampa autoarticulada compartimento inoxidável com profundidade de 200 mm
- Chaminé de ferro fundido esmaltado à prova de riscos
- Controle termostático de temperatura
- Aquecedor tubular inoxidável do compartimento de cozimento
- Temperatura ajustável, 50°C - 300°C
- Luzes de aviso ao atingir a temperatura desejada
- Elevação manual com volante

#### DETALLES DEL PRODUCTO

- Caldera inoxidable
- Interruptor de seguridad que para el funcionamiento cuando se retira la caldera de cocción
- Termostato de seguridad.
- Llama del piloto y válvula con termopar
- Encendido piezoeléctrico del quemador
- Tubo de llenado de agua controlado desde el panel frontal
- Profundidad de la cubeta de acero inoxidable con cubierta bisagrada es de 200 mm
- Chimenea de hierro fundido esmaltado que es inoxidable y no se raya
- Control termostático de la temperatura
- Calentadores con tubos de acero inoxidable bajo la cubeta de cocción
- Temperatura ajustable de 50 °C - 300 °C
- Luces de advertencia cuando se alcanza la temperatura deseada
- Extracción manual con manija

Model	Visual	Dim (mm) LxDxH		Power	Gross Weight	Gross Volume	Electrical Inlet	Gas Inlet	Capacity (lt)	Price
G7TD200E		800x730x900		9 kw	130 kg	0,95 m <sup>3</sup>	400 V 3N PE	-	60 lt	2.882 €
G7TD200G		800x730x900		18 kw	130 kg	0,95 m <sup>3</sup>	230V 1N PE 50-60 hz	R 1/2"	60 lt	3.097 €

# cooking

french fry warmer / chauffe frite / friet bassin  
aquecedor de batatas / conservador de patatas

# KUSINA®

## 700 SERIES



### General Features

- Stainless steel body
- Easy to clean and hygienic
- Ergonomic design
- Adjustable legs
- Long life



### Caractéristiques Générales

- Corps en acier inoxydable
- Facile à nettoyer hygiénique
- Conception ergonomique
- Pieds réglables
- Longue durée



### Características Gerais

- Corpo de aço inoxidável
- Higiênica, fácil de limpar
- Design econômico
- Pés ajustáveis
- Longa durabilidade



### Características Generales

- Estructura de acero inoxidable
- Fácil de limpiar, higiénica
- Diseño ergonómico
- Pies ajustables
- Larga vida útil



G7D100E

#### PRODUCT HIGHLIGHTING DETAILS

- GN 1/1 Container with oil strainer
- Cupboard with door
- The fried potatoes keep warm by custom porcelain infrared heater
- Removable and easy to clean container

#### DÉTAILS DU PRODUIT

- Bac GN 1/1 avec filtre à huile
- Armoire avec porte
- La chaleur est fournie par les radiateurs infrarouges en porcelaine spéciale
- Réservoir du chauffe frite amovible et facile à nettoyer sauce non chauffée

#### DETALHES DO PRODUTO

- Compartimento para batatas com peneira de óleo GN 1/1
- Gabinete inferior com portas
- Com o aquecimento infravermelho por porcelana especial mantém a temperatura das batatas fritas
- Compartimento de batatas removível e de fácil limpeza

#### DETALLES DEL PRODUCTO

- Cubeta de patatas GN 1/1 con filtro de aceite
- Armario inferior con puertas
- Mantiene caliente a las patatas fritas mediante los calentadores infrarrojos de porcelana especial
- Cubeta desmontable y fácil de limpiar para conservar patatas



Model	Visual	Dim (mm) LxDxH		Power	Gross Weight	Gross Volume	Electrical Inlet	Price
G7D100E		400x730x900		0,85 kw	65 kg	0,45 m <sup>3</sup>	230 V 1N PE	595 €

# cooking

sauce bain marie / bain-marie pour sauce /  
banho-maria para molhos / baño maria

# KUSINA®

## 700 SERIES



### General Features

- Stainless steel body
- Easy to clean and hygienic
- Ergonomic design
- Adjustable legs
- Long life
- Bleed valve



### Caractéristiques Générales

- Corps en acier inoxydable
- Facile à nettoyer, hygiénique
- Conception ergonomique
- Pieds réglables
- Longue durée



### Características Gerais

- Corpo de aço inoxidável
- Higiênica, fácil de limpar
- Design econômico
- Pés ajustáveis
- Longa durabilidade
- válvula de drenagem



### Características Generales

- Estructura de acero inoxidable
- Fácil de limpiar, higiénica
- Diseño ergonómico
- Pies ajustables
- Larga vida útil
- Válvula de alivio



G7S100E



G7S200E

#### PRODCUT HIGHLIGHTING DETAILS

- The dimensions of the pool are according to the GN Sizes
- Unscratchable and enameled cast iron back grate
- Cupboard with door
- Thermostatic temperature control
- Stainless steel tube heaters under the pool
- Indicator lights when reaching to the required temperature
- Operating temperature range (30-90 °C)

#### DÉTAILS DU PRODUIT

- Bacs conformes aux dimension de GN
- Cheminée en fonte émaillée inoxydable et anti-rayures
- Armoire inférieur à porte
- Contrôle de la température thermostatique
- Tube de résistance inoxydable sous le bac
- Plage de température de fonctionnement (30-90 °C)

#### DETALHES DO PRODUTO

- Compartimento de aquecimento de acordo com as medidas GN
- Chaminé de ferro fundido esmaltado à prova de riscos
- Gabinete inferior com portas
- Controle de aquecimento termostático
- Resistências tubular inoxidável no compartimento inferior
- Faixa de temperatura operacional (30 -90°C)

#### DETALLES DEL PRODUCTO

- Cubeta de calentamiento con las dimensiones de GN
- Chimenea de hierro fundido esmaltado inoxidable y no se raya
- Armario inferior con puertas
- Control termostático de temperatura
- Calentadores de tubo bajo de la cubeta
- Rango de la temperatura de funcionamiento (30-90 °C)



Model	Visual	Dim (mm) LxDxH		Power	Weight	Volume	Electrical Inlet	Tank Capacity	Price
G7S100E		400x730x900		1,5 kw	36 kg	0,38 m <sup>3</sup>	230 V 1N PE	GN 1/3 150 mm x 1 GN 2/3 150 mm x 1	786 €
G7S200E		800x730x900		3 kw	65 kg	0,75 m <sup>3</sup>	230 V 1N PE	GN 1/1 150 mm x1 GN 1/4 150 mm x3	1.009 €

# cooking

lavastone griddle / grille de pierre de lave / churrasqueira de obsidiana  
plancha / plancha con piedra volcánica con piedra volcánica

# KUSINA®

## 700 SERIES



### General Features

- Stainless steel body
- Easy to clean and hygienic
- Ergonomic design
- Adjustable legs
- Long life
- Available LPG or natural gas



### Caractéristiques Générales

- Corps en acier inoxydable
- Facile à nettoyer, hygiénique
- Valve à gaz avec soupape de sécurité
- Conception ergonomique
- Pieds réglables
- Longue durée
- Peut fonctionner au GPL et au gaz naturel



### Características Gerais

- Corpo de aço inoxidável
- Higiênica, fácil de limpar
- Válvula de segurança registro de gás
- Design económico
- Pés ajustáveis
- Longa durabilidade
- Funciona com gás natural e gás GLP



### Características Generales

- Estructura de acero inoxidable
- Fácil de limpiar, higiénica
- Válvula de gas, válvula de seguridad
- Diseño ergonómico
- Pies ajustables
- Larga vida útil
- Adecuada a funcionar con gas natural y el GLP



G7L100G



G7L200G

#### PRODCUT HIGHLIGHTING DETAILS

- Long life cast iron griddle under the lavstones
- Homogenous cooking surface
- Stainless steel oil collection drawer is placed in cupboard
- Stainless steel V-shape grilling grate
- Waste oil drawer
- Piezo-electric burner ignition
- Independent two cooking areas of surface
- Insulation to prevent overheating of the body and reduce energy losses
- Slightly sloped cooking surface, easy and convenient for cleaning, with liquid discharge hole

#### DETALHES DO PRODUTO

- Grelha inferior feita em ferro fundido obsidiana de longa durabilidade
- Superfície de cozimento homogêneo
- Gaveta coletora de gordura em aço inoxidável localizada dentro do gabinete
- Grelha de aço em forma de "v"
- Compartimento de óleo residual queimador de acendimento piezoelétrico
- Dois compartimentos de cozimento independentes
- Isolamento reductor do nível de perda de aquecimento e aquecimento da área das chapas de metal
- Com uma leve inclinação da superfície de cozimento e orifício para escoamento de líquidos proporcionando uma limpeza fácil e confortável

#### DÉTAILS DU PRODUIT

- Grille inférieure de pierre de lave de longue durée en fonte
- Surface de cuisson homogène
- Tiroir de récupération des graisses en acier inoxydable placé à l'intérieur du placard
- Grille en acier en forme "v"
- Réservoir d'huile usée, brûleur à l'allumage piézoélectrique
- Deux zones de cuisson indépendantes
- L'isolation de l'appareil prévient la perte de chaleur au maximum
- Surface de cuisson en pente douce pour un nettoyage facile et pratique avec trou de décharge de liquide

#### DETALLES DEL PRODUCTO

- Rejilla inferior de piedra volcánica hecha de hierro fundido con larga vida útil
- Superficie homogénea de cocción
- Cajón de recogida de grasas de acero inoxidable colocado dentro del armario
- Rejilla de de cocción de acero en forma "V"
- Tanque del aceite usado • Encendido piezoeléctrico del quemador
- Dos zonas de cocción independientes
- Aislamiento que minimiza al calentamiento de las placas en el entorno y minimiza la pérdida de calor
- Superficie de cocción ligeramente inclinada para una limpieza fácil y cómoda con agujero de descarga



Model	Visual	Dim (mm) LxDxH		Power	Gross Weight	Gross Volume	Gas Inlet	Price
G7L100G		400x730x900		9 kw	76 kg	0,45 m <sup>3</sup>	R ½ "	1.004 €
G7L200G		800x730x900		18 kw	128 kg	0,90 m <sup>3</sup>	R ½ "	1.451 €

# cooking

vapor grill / grill vapeur à gaz / churrasqueira com água / parilla con agua

# KUSINA®

## 700 SERIES



### General Features

- Stainless steel body
- Easy to clean and hygienic
- Ergonomic design
- Adjustable legs
- Long life
- Water drainage top
- Water drawer
- Long life



### Caractéristiques Générales

- Corps en acier inoxydable
- Facile à nettoyer, hygiénique
- Valve à gaz avec soupape de sécurité
- Conception ergonomique
- Pieds réglables
- Longue durée
- Peut fonctionner au GPL et au gaz naturel
- Tiroir de l'eau



### Características Gerais

- Corpo de aço inoxidável
- Higiênica, fácil de limpar
- Design ergonômico
- Pés ajustáveis
- Longa durabilidade
- Válvula de escape para drenagem
- Gaveta para água



### Características Generales

- Cuerpo de acero inoxidable
- Fácil de limpiar e higiénico
- Diseño ergonómico
- Patas ajustables
- Larga vida
- Válvula de drenaje
- Compartimento de agua

### PRODCUT HIGHLIGHTING DETAILS

- Thanks to water reservoir under cast cooking surface, vaporization is provided during cooking process and dehydration of food being cooked is prevented.
- Special design griddles on cooking surface can be removed easily. This feature provides convenience for cleaning and maintenance.
- The water reservoir that can be interfered from front face has drawers and it can be removed easily.
- Residuary oil flows through cooking grill and it goes to the water reservoir. So inflammation of oil is prevented.
- This version has two separate firing zones.
- Isolation that minimizes heating of periphery metal sheet and heat abduction.
- Mouldings that are designed specially and that breaks fires.
- Castings resistant to high temperature

### DETALHES DO PRODUTO

- Graças ao reservatório de água encontrado sob a superfície de cozimento em ferro fundido a vaporização é proporcionada durante o cozimento, o que impede que os alimentos fiquem secos.
- O design especial da superfície de cozimento permite a remoção fácil das grelhas em ferro fundido. Essa característica proporciona facilidade na limpeza e manutenção do aparelho.
- Na parte frontal com o auxílio do depósito de água com gaveta de fácil remoção.
- O excesso de gordura residual do cozimento escorre da grelha para o depósito d'água.
- Versão com duas áreas de cozimento distintas
- Isolamento redutor do nível de perda de aquecimento e aquecimento da área das chapas de metal
- Molduras que foram desenhadas especialmente e cortadores de fogo.
- Peças fundidas de alta resistência ao calor



G7V100G



G7V200G



### DÉTAILS DU PRODUIT

- Avec réservoir à eau sous la plaque de cuisson en fonte, la vaporisation de surface est fournie en continue empêchant la déshydratation des aliments.
- Grilles de conception spéciale sur la surface de cuisson peuvent être enlevées facilement. Cette fonctionnalité facilite le nettoyage et l'entretien.
- Le réservoir d'eau à tiroir avant peut être enlevé facilement.
- Le flux d'huile résiduel passe par la grille de cuisson vers le réservoir d'eau empêchant l'huile de brûler.
- Cette version dispose de deux zones de cuisson séparées.
- L'isolation réduit la chaleur sur le pourtour de la grille.
- La conception du pourtour réduit la survenue des feux de cuisson.
- Fontes résistantes à la température élevée

### DETALLES DEL PRODUCTO

- Como el resultado del recipiente de agua bajo la superficie de cocción; se proporciona vaporización y se evita secado de los alimentos durante la cocción
- Las parillas de diseño especial en la superficie de cocción se pueden quitar fácilmente. Esta característica proporciona la facilidad de limpieza y mantenimiento.
- Recipiente de agua puede ser interferido de la parte frontal y tiene una estructura con cajones y se puede quitar fácilmente.
- Aceite residual fluye a través de la rejilla de cocción y llega al recipiente de agua. Así se evita la inflamación del aceite.
- Versión con dos zonas de cocción independientes.
- Aislamiento que minimiza el calentamiento de la chapa periferia y la pérdida de calor.
- Molduras que evitan los incendios están diseñados especialmente.
- Piezas de fundición de alta resistencia al calor

Model	Visual	Dim (mm) LxDxH		Power	Gross Weight	Gross Volume	Gas Inlet	Price
G7V100G		400x730x900		10 kW	105 kg	0,45 m <sup>3</sup>	R ½ "	1.227 €
G7V200G		800x730x900		20 kW	170 kg	0,95 m <sup>3</sup>	R ½ "	1.991 €

# cooking

chinese cooker / gazinière chinoise / fogão chinês / cocina china

# KUSINA®

## 700 SERIES

CE



### General Features

- Stainless steel body
- Easy to clean and hygienic
- Ergonomic design
- Adjustable legs
- Long life
- Castings resistant to high temperature



### Caractéristiques Générales

- Corps en acier inoxydable
- Facile à nettoyer, hygiénique
- Valve à gaz avec soupape de sécurité
- Conception ergonomique
- Pieds réglables
- Longue durée
- Peut fonctionner au GPL et au gaz naturel
- Fontes résistantes à la température élevée



### Características Gerais

- Corpo de aço inoxidável
- Higiênica, fácil de limpar
- Design económico
- Pés ajustáveis
- Longa durabilidade
- Peças fundidas de alta resistência ao calor



### Características Generales

- Estructura de acero inoxidable
- Fácil de limpiar, higiénica
- Diseño ergonómico
- Pies ajustables
- Larga vida útil
- Piezas de fundición de alta resistencia al calor



G7W100G



Model	Visual	Dim (mm) LxDxH	Burners kW	Power	Gross Weight	Gross Volume	Gas Inlet	Price
G7W100G		400x730x900		10 kW	50 kg	0,38 m <sup>3</sup>	R ½ "	853 €

# cooking

neutral unit / élément intermédiaire /  
bancada para descanso / mesa de soporte

# KUSINA®

## 700 SERIES

CE



### General Features

- Stainless steel body
- Easy to clean and hygienic
- Ergonomic design
- Adjustable legs
- Long life



### Caractéristiques Générales

- Corps en acier inoxydable
- Facile à nettoyer, hygiénique
- Conception ergonomique
- Pieds réglables
- Longue durée



### Características Gerais

- Corpo de aço inoxidável
- Higiênica, fácil de limpar
- Design económico
- Pés ajustáveis
- Longa durabilidade



### Características Generales

- Estructura de acero inoxidable
- Fácil de limpiar, higiénica
- Diseño ergonómico
- Pies ajustables
- Larga vida útil



G7T100N



G7T200N

#### PRODUCT HIGHLIGHTING DETAILS

- Cupboard with door
- Optional Drawer System
- Unscratchable and enameled cast iron back grate

#### DÉTAILS DU PRODUIT

- Armoire inférieure à porte
- La version avec tiroir est optionnelle
- Cheminée en fonte émail, inoxydable et anti-rayures

#### DETALHES DO PRODUTO

- Gabinete inferior com portas
- Versão com gavetas opcionais
- Chaminé de ferro fundido esmaltado à prova de riscos

#### DETALLES DEL PRODUCTO

- Armario inferior con puertas
- Versión opcional con cajones
- Chimenea de hierro fundido esmaltado inoxidable y no se raya



Model	Visual	Dim (mm) LxDxH		Gross Weight	Gross Volume	Price
G7T100N		400x730x900		40 kg	0,45 m <sup>3</sup>	415 €
G7T200N		800x730x900		50 kg	0,95 m <sup>3</sup>	516 €

***KUSINA***<sup>®</sup>



**700 S SERIES**



# cooking

gas range / cuisinière à gaz / fogão à gás /  
cocina a gas

**KUSINA®**  
**700S** SERIES



## General Features

- Stainless steel body
- Easy to clean and hygienic
- Ergonomic design
- Long life
- High efficiency burner



## Caractéristiques Générales

- Corps en acier inoxydable
- Facile à nettoyer, hygiénique
- Valve à gaz avec soupape de sécurité
- Conception ergonomique
- Pieds réglables
- Longue durée
- Brûleurs à haut rendement
- Four isolé



## Características Gerais

- Corpo de aço inoxidável
- Higiênica, fácil de limpar
- Válvula de segurança registro de gás
- Design econômico
- Pés ajustáveis
- Longa durabilidade
- Queimadores de alta eficiência
- Forno com isolamento



## Características Generales

- Estructura de acero inoxidable
- Fácil de limpiar, higiénica
- Válvula de gas, válvula de seguridad
- Diseño ergonómico
- Pies ajustables
- Larga vida útil
- 2 o 4 fuegos abiertos
- Horno aislado

### PRODCUT HIGHLIGHTING DETAILS

- 2/4 and 6 Burners , with or without oven
- Easy to clean and simple maintenance with removable Burner Bottom Tray
- Unscratchable and enameled cast iron top grates.
- Nickel coated cast iron burners
- Protected Pilot Flame
- With oven or cupboards
- Enamel coated bottom steel sheet
- The body of the oven is made of aluminium coated sheet metal
- Self stabilizing flame
- Removable and easy to clean stainless steel oven shelves
- Thermostatic temperature control with safety valve and thermocouple

### DÉTAILS DU PRODUIT

- 2,4 et 6 brûleurs, plateau inférieur du brûleur amovible, permettant un nettoyage facile, l'entretien et la réparation
- Cheminée et grille supérieures émaillés, en fonte anti-rayures, faciles à nettoyer. Les fours sont en fonte nicklée. Lampe-témoin protégée.
- Fourneau ou armoire inférieur- l'intérieur de fourneau est conforme à la dimension GN 2/1- le tôle de plancher du four est en acier émaillé corps du four
- Fabriqué en tôle revêtu d'aluminium
- La porte est acier inoxydable, isolée à double membranes, avec lampe témoin stabilisée, les grilles en acier inoxydables amovibles et faciles à nettoyer
- Robinet à gaz avec vanne thermostatique de sécurité de réglage de la température- veilleuse du four de l'allumage piézoélectrique

### DETALHES DO PRODUTO

- 2,4 e 6 queimadores, fácil limpeza e manutenção proporcionadas pelo queimador e bandeja inferior removíveis
- Chaminé e grelha do fogão de ferro fundido esmaltado à prova de riscos de fácil limpeza
- bocas de ferro fundido niquelado
- Chama-piloto protegido
- Com forno ou com gabinete inferior
- Chapa do fundo do forno esmaltada chapa do corpo do forno feita de alumínio
- Prateleiras do forno em aço inoxidável removíveis de fácil limpeza
- Temperatura ajustável válvula de segurança e registro de gás
- Forno com acendimento piezoelétrico

### DETALLES DEL PRODUCTO

- Recipiente inferior de quemador con 2.4 y 6 fuegos abiertos, facil que limpieza, mantenimiento y reparación
- Chimenea y rejilla superior de hierro fundido con recubrimiento de esmalte que se puede limpiar fácilmente y no se raya
- Quemadores niquelados de hierro fundido
- Llama piloto con protección
- Con horno o armario inferior
- Placa de fondo de hierro esmaltado del horno
- Estructura de horno hecho de placa recubierta con aluminio
- Puerta aislada de doble pared de acero inoxidable
- Llama estabilizada de la luz piloto del horno
- Válvula termostático de gas con válvula de seguridad, temperatura ajustable
- Encendedor de horno con piloto piezoeléctrico.
- Thermostatic temperature control with safety valve and thermocouple



7RC100G  
reduction

# cooking

gas range / cuisinière à gaz/ fogão à gás/  
cocina a gas

# KUSINA®

## 700S SERIES

CE



G7K100G-S









G7K200G-S

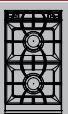

G7K201G-S

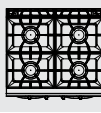

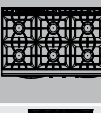
G7K101G-S

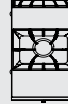
Model	Visual	Dim (mm) LxDxH	Burners kW	Power	Gross Weight	Gross Volume	Gas Inlet	Price
G7K100G-S		400x730x300	2x6.5 	13 kw	41 kg	0,24 m <sup>3</sup>	R ½ "	818,€
G7K200G-S		800x730x300	4x6.5 	26 kw	60 kg	0,36 m <sup>3</sup>	R ½ "	1.257 €
G7K201G-S		1200x730x300	6x6,5 	39 kw	105 kg	0,59 m <sup>3</sup>	R ½ "	1.601 €
G7K101G-S		400x730x300	1x6,5 	6,5 kw	40 kg	0,36 m <sup>3</sup>	R ½ "	745 €

# cooking

electrical range/ cuisinière électrique / fogão elétrico / cocina eléctrica

# KUSINA®

## 700S SERIES



### General Features

- Stainless steel body
- Easy to clean and hygienic
- Ergonomic design
- Adjustable legs
- Long life



### Caractéristiques Générales

- Corps en acier inoxydable
- Facile à nettoyer, hygiénique
- Conception ergonomique
- Pieds réglables
- Longue durée
- Four avec isolation



### Características Gerais

- Corpo de aço inoxidável
- Higiênica, fácil de limpar
- Válvula de segurança registro de gás
- Design económico
- Pés ajustáveis
- Longa durabilidade



### Características Generales

- Estructura de acero inoxidable
- Fácil de limpiar, higiénica
- Diseño ergonómico
- Pies ajustables
- Larga vida útil



G7K100E-S



G7K200E-S

#### PRODUCT HIGHLIGHTING DETAILS

- 2 or 4 heating plates,
- Ø 180 mm and Ø 230 mm - two types of cooking plates
- Unscratchable enameled cast iron back grate
- With oven or cupboards
- Enamel coated bottom steel sheet
- Adjustable thermostatic temperature control

#### DÉTAILS DU PRODUIT

- Modeles de 2et 4 plaques chauffantes.
- 2 types de plaques de cuisson de Ø 180 et Ø 230 mm
- Cheminée en fonte émaillée inoxydable et anti-rayures
- Le tole de plancher de four en acier émaillé
- Signal optique on-off à l'atteint de la température désirée - corps du four en tôle revêtue d'aluminium
- Chauffe-tuyau inoxydable
- Contrôle de la température du thermostat réglable
- Signal optique à l'atteint de la temperature désirée

#### DETALHES DO PRODUTO

- Com 2 ou 4 placas de aquecimento, modelos com ou sem forno
- Dois tipos de placa com aproximadamente Ø 180 e Ø 230 mm
- Chaminé de ferro fundido esmaltado à prova de riscos
- Chapa do fundo do forno esmaltada
- Luzes de aviso liga/desliga ao atingir a temperatura desejada
- Resistência cilíndrica inoxidável
- Controle ajustável de temperatura termostático
- Luzes de aviso ao atingir a temperatura desejada

#### DETALLES DEL PRODUCTO

- Modelos con 2,4 placas calientes, con/sin horno
- Dos tipos de placas calientes de Ø 180 y Ø 230 mm
- Chimenea de hierro fundido esmaltado que es inoxidable y no se raya
- Con horno o armario inferior
- Luces de apagado - encendido cuando alcanza la temperatura deseada
- Calentadores de tubos de acero inoxidable
- Control termostático con temperatura ajustable
- Luces de advertencia cuando se alcanza la temperatura deseada



Model	Visual	Dim (mm) LxDxH	Plates kW	Power	Gross Weight	Gross Volume	Electrical Inlet	Price	
G7K100E-S		400x730x300	1x1,5 1x2		3,5 kw	31 kg	0,21 m³	230 V 1N PE	491 €
G7K200E-S		800x730x300	2x1,5 2x2		7 kw	60 kg	0,36 m³	400 V 3N PE	767 €

# cooking

pasta cooker/ cusieur à pâtet /  
macaroni cozedor de massas/ cocedor de pasta

# KUSINA®

## 700S SERIES



### General Features

- Stainless steel body
- Easy to clean and hygienic
- Ergonomic design
- Adjustable legs
- Long life
- Single or double cooking containers



### Caractéristiques Générales

- Corps en acier inoxydable
- Facile à nettoyer, hygiénique
- Thermostat de sécurité
- Conception ergonomique
- Pieds réglables
- Longue durée
- 1 ou 2 bacs



### Características Gerais

- Corpo de aço inoxidável
- Higiênica, fácil de limpar
- Termostato de segurança
- Design econômico
- Pés ajustáveis
- Longa durabilidade
- Compartimento Simples ou Duplo



### Características Generales

- Estructura de acero inoxidable
- Fácil de limpiar, higiénica
- Termostato de seguridad
- Diseño ergonómico
- Pies ajustables
- Larga vida útil
- Cubierta Simple y Doble



G7M100E-S



G7M200E-S

#### PRODUCT HIGHLIGHTING DETAILS

- Working and safety thermostatic temperature control
- Cooking container with overflow drain
- Stainless steel tube heaters
- Indicator lights when reaching to the required temperature
- Operating temperature range (0-120 °C)

#### DÉTAILS DU PRODUIT

- Contrôle de la température de thermostat de fonctionnement et de sécurité
- Lumière de on-off à l'atteinte de la température
- Bac de trop-plein lié au tuyau d'évacuation
- Chauffage du tube en acier inoxydable
- Plage de température de fonctionnement (0-120 °C)

#### DETALHES DO PRODUTO

- Controle de funcionamento e segurança termostático
- Luzes indicadoras de liga/desliga ao atingir aquecimento
- Compartimento com escoamento
- Aquecedor tubular de aço inoxidável
- Faixa de temperatura operacional (0-120°C)

#### DETALLES DEL PRODUCTO

- Control de la temperatura con termostato de funcionamiento y termostato de seguridad
- Cubeta con desagüe con rebosadero de desagüe
- Calentador de tubo de acero inoxidable
- Rango de la temperatura de funcionamiento (0-120 °C)



Basket Combination

Model	Visual	Dim (mm) LxDxH		Power	Gross Weight	Gross Volume	Electrical Inlet	Tank Capacity	Capacity (lt)	Price
G7M100E-S		400x730x300		10 kw	35 kg	0,19 m <sup>3</sup>	400 V 3N PE	145x270x150 135x180x150x2	14 lt	1.129 €
G7M200E-S		800x730x300		20 kw	60 kg	0,21 m <sup>3</sup>	400 V 3N PE	145x270x150x2 135x180x150x4	2x14 lt	1,759 €

# cooking

fry top/ grille / churrasqueira/ plancha

# KUSINA®

## 700S SERIES

CE



### General Features

- Stainless steel body
- Easy to clean and hygienic
- Safety gas valve
- Ergonomic design
- Adjustable legs
- Long life
- High efficiency burner
- Available lpg or natural gas



### Caractéristiques Générales

- Corps en acier inoxydable
- Facile à nettoyer, hygiénique
- Valve à gaz avec sopapae de sécurité
- Conception ergonomique
- Pieds réglables
- Longue durée
- Brûleurs à haut rendement
- Peut fonctionner au GPL et au gaz naturel



### Características Gerais

- Corpo de aço inoxidável
- Higiênica, fácil de limpar
- Válvula de segurança registro de gás
- Design económico
- Pés ajustáveis
- Longa durabilidade
- Queimadores de alta eficiência
- Funciona com gás natural ou com gás GPL



### Características Generales

- Estructura de acero inoxidable
- Fácil de limpiar, higiénica
- Válvula de gas ,válvula de seguridad
- Diseño ergonómico
- Pies ajustables
- Larga vida útil
- Puede funcionar con gas natural y GLP



### PRODCUT HIGHLIGHTING DETAILS

- Smooth, ribbed and ½ smooth + ½ ribbed fry top plates versions
- ST 52 steel or hard chromium coated steel 15 mm thick griddle plate
- Cooking surface perimeter is 3 mm thick stainless steel
- Slightly sloped cooking surface, easy and convenient for cleaning, with liquid discharge hole.
- Homogenous heated cooking surface
- Special machined grooves
- Waste oil drawer
- Thermostatic temperature control
- Thermocouple safety device connected to the burner
- Piezo-electric burner ignition
- Double independent cooking surface
- Insulation to prevent overheating of the body and reduce energy losses
- Operating temperature range (50-300 °C)

### DÉTAILS DU PRODUIT

- Versions lisse, nervurée et mixte de la surface de cuisson
- Les grilles sont soit en acier ST 52 de 15 mm d'épaisseur soit en acier et chromé dur
- Le pourtour de surface de cuisson est en acier inoxydable et de 3mm d'épaisseur
- Tiroir de récupération des graisses en acier inoxydable placé à l'intérieur du placard
- Surface de cuisson en pente douce pour le nettoyage facile et pratique
- Trou de décharge du liquide - surface de cuisson avec chauffe homogène
- Rainures avec traitement spécial - Réservoir d'huile usée
- Contrôle de la température thermostatique
- Le système de sécurité à thermocouple lié au brûleur
- Un système de sécurité à thermocouple est lié au brûleur
- Brûleur à l'allumage piézoélectrique avec versions à une ou deux zones de cuissons indépendantes
- L'isolation de l'appareil prévient la perte de chaleur au maximum
- Brûleur à l'allumage piézoélectrique à deux zones de cuissons indépendantes
- Plage de température de fonctionnement (50-300 °C)

### DETALHES DO PRODUTO

- Nas versões com superfície de cozimento plana, com ranhuras ou com ranhuras + plana
- Churrasqueira com 15 mm de espessura aço st 52 ou revestido de cromo duro aço platinum
- Área da superfície de cozimento em aço inoxidável com espessura de 3mm
- Superfície de cozimento com uma leve inclinação para uma limpeza fácil e confortável
- Orifício para escoamento de líquidos superfície de cozimento com aquecimento homogêneo
- Ranhuras com funcionalidades especiais
- Recipiente de óleo residual
- Controle termostático de temperatura
- Sistema de segurança termopar ligado ao queimador
- Queimadores com acionamento piezoelétrico nas versões com uma ou duas áreas de cozimento independentes
- Isolamento redutor do nível de perda de aquecimento e aquecimento da área das chapas de metal
- Queimadores com acionamento piezoelétrico duas áreas de cozimento independentes
- Isolamento redutor do nível de perda de aquecimento e aquecimento da área das chapas de metal
- Orifício para escoamento de líquidos
- Isolamento redutor do aquecimento da área das chapas e perda de temperatura
- Faixa de temperatura operacional (50-300°C)

### DETALLES DEL PRODUCTO

- Versiones de la superficie de cocción son plana, acanalada o acanalada
- Rejillas de acero platina cromadas con cromo duro o acero de st 52 con espesor de 15 mm
- Entorno de la superficie de cocción es de acero inoxidable de 3 mm de espesor
- Superficie de cocción ligeramente inclinada para una limpieza fácil y cómoda
- Orificio de drenaje de líquido
- Superficie de cocción que ofrece una cocción homogénea
- Ranuras procesadas especialmente
- Tanque del aceite usado
- Control termostático de la temperatura
- El sistema de seguridad con termopar conectado al quemador
- Versiones de zonas de cocción con una o dos zonas independientes y con quemados de encendido piezoeléctrico
- Aislamiento que minimiza al calentamiento de las placas en el entorno y minimiza la pérdida de calor
- Dos zonas de cocción con quemados de encendido piezoeléctrico
- Orificio de drenaje de líquido
- Rango de la temperatura de funcionamiento (30-90 °C)

# cooking

fry top / grille / churrasqueira / plancha

# KUSINA®

## 700S SERIES

CE



G7I200E-S



G7I210E-S



G7I220E-S



G7I200G-S



G7I210G-S



G7I220G-S



G7I100E-S



G7I110E-S



G7I100G-S



G7I110G-S

Model	Visual	Dim (mm) LxDxH		Power	Gross Weight	Gross Volume	Gas Inlet	Electrical Inlet	Smooth	Ribbed	Price
G7I200E-S		800x730x300		7,2 kw	119 kg	0,36 m³	-	400 V 3N PE	✓		1.118 €
G7I210E-S		800x730x300		7,2 kw	115 kg	0,36 m³	-	400 V 3N PE		✓	1.366 €
G7I220E-S		800x730x300		7,2 kw	115 kg	0,36 m³	-	400 V 3N PE	✓	✓	1.268 €
G7I200G-S		800x730x300		13 kw	115 kg	0,36 m³	R 1/2"	-	✓		1.105 €
G7I210G-S		800x730x300		13 kw	115 kg	0,36 m³	R 1/2"	-		✓	1.391 €
G7I220G-S		800x730x300		13 kw	115 kg	0,36 m³	R 1/2"	-	✓	✓	1.295 €
G7I100E-S		400x730x300		3,6 kw	70 kg	0,21 m³	-	400 V 3N PE	✓		791 €
G7I110E-S		400x730x300		3,6 kw	70 kg	0,19 m³	-	400 V 3N PE	-	✓	1.050 €
G7I100G-S		400x730x300		6,5 kw	70 kg	0,19 m³	R 1/2"	-	✓	-	737 €
G7I110G-S		400x730x300		6,5 kw	70 kg	0,19 m³	R 1/2"	-		✓	878 €

# cooking chromium plate

fry top / grille / churrasqueira / plancha

# KUSINA®

## 700S SERIES



G7I200E-SC



G7I210E-SC



G7I220E-SC



G7I200G-SC



G7I210G-SC



G7I220G-SC



G7I1100E-SC



G7I1110E-SC



G7I1100G-SC



G7I1110G-SC

Model	Visual	Dim (mm) LxDxH		Power	Gross Weight	Gross Volume	Gas Inlet	Electrical Inlet	Smooth	Ribbed	Price
G7I200E-SC		800x730x300		7,2 kw	119 kg	0,36 m³	-	400 V 3N PE	✓		1.597 €
G7I210E-SC		800x730x300		7,2 kw	115 kg	0,36 m³	-	400 V 3N PE		✓	1.845 €
G7I220E-SC		800x730x300		7,2 kw	115 kg	0,36 m³	-	400 V 3N PE	✓	✓	1.747 €
G7I200G-SC		800x730x300		13 kw	115 kg	0,36 m³	R 1/2 "	-	✓		1.583 €
G7I210G-SC		800x730x300		13 kw	115 kg	0,36 m³	R 1/2 "	-		✓	1.870 €
G7I220G-SC		800x730x300		13 kw	115 kg	0,36 m³	R 1/2 "	-	✓	✓	1.774 €
G7I1100E-SC		400x730x300		3,6 kw	70 kg	0,21 m³	-	400 V 3N PE	✓		1.060 €
G7I1110E-SC		400x730x300		3,6 kw	70 kg	0,19 m³	-	400 V 3N PE	-	✓	1.319 €
G7I1100G-SC		400x730x300		6,5 kw	70 kg	0,19 m³	R 1/2 "	-	✓	-	1.005 €
G7I1110G-SC		400x730x300		6,5 kw	70 kg	0,19 m³	R 1/2 "	-		✓	1.147 €

# cooking

fryer / friteuse / fritadeira / freidora

# KUSINA®

## 700S SERIES



### General Features

- Stainless steel body
- Easy to clean and hygienic
- Ergonomic design
- Adjustable legs
- Long life
- Homogenous cooking surface
- Available lpg or natural gas
- Safety gas valve



### Caractéristiques Générales

- Corps en acier inoxydable
- Facile à nettoyer, hygiénique
- Conception ergonomique
- Pieds réglables
- Longue durée
- Corps monobloc
- Valve à gaz avec sopapae de sécurité
- Thermostat de sécurité
- Différentes capacités sont disponibles



### Características Gerais

- Corpo de aço inoxidável
- Higiênica, fácil de limpar
- Design económico
- Pés ajustáveis
- Longa durabilidade
- Corpo monobloco
- Válvula de segurança registro de gás
- Termostato de segurança



### Características Generales

- Estructura de acero inoxidable
- Fácil de limpiar, higiénica
- Diseño ergonómico
- Pies ajustables
- Larga vida útil
- Estructura monobloque
- Válvula de gas ,válvula de seguridad
- Termostato de seguridad



G7F100E-S



G7F200E-S

#### PRODCUT HIGHLIGHTING DETAILS

- Single or double container models
- Unscratchable and stainless enameled cast back grate
- Thermostatic temperature control
- Stainless steel baskets
- Adjustable temperature
- Operation and heating control indicator lights
- Stainless steel tube heaters
- Operating temperature range (0-180 °C)

#### DETALHES DO PRODUTO

- Nas versões com compartimento simples ou duplo
- Chaminé de ferro fundido esmaltado à prova de riscos
- Queimador de ignição piezoelétrico
- Controle de temperatura termostático
- Cestos inoxidáveis
- Temperatura de aquecimento ajustável
- Sistema de combustão à gás que proporciona alta eficiência
- Luzes indicadoras de acionamento
- Resistência tubular inoxidável
- Faixa de temperatura operacional (0 -180°C)

#### DÉTAILS DU PRODUIT

- Modèles avec 1 ou 2 bacs
- Cheminée en fonte émaillé inoxydable et anti-rayures
- Brûleur à l'allumage piézoélectrique
- Contrôle de la température du thermostat
- Paniers en acier inoxydable
- Température réglable
- Système de combustion du gaz à grande efficacité
- Indicateurs de fonctionnement et de température
- Résistance de tuyau inoxydable
- Plage de température de fonctionnement (0-180 °C)

#### DETALLES DEL PRODUCTO

- Versiones de simple o doble cubetas
- Chimenea de hierro fundido esmaltado inoxidable y no se raya
- Encendido piezoeléctrico del quemador
- Control termostático de temperatura
- Cestas inoxidables
- Temperatura ajustable
- Sistema de quema de gas de alta eficiencia
- Indicadores de funcionamiento y de la temperatura
- Rango de la temperatura de funcionamiento (0-180 °C)

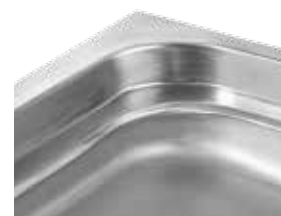

Model	Visual	Dim (mm) LxDxH		Power	Gross Weight	Gross Volume	Electrical Inlet	Basket Size	Capacity	Price
G7F100E-S		400x730x300		7,5 kw	43 kg	0,19 m³	400 V 3N PE	200x280x100	10 lt	976 €
G7F200E-S		800x730x300		15 kw	70 kg	0,36 m³	400 V 3N PE	200x280x100x2	2x 10 lt	1.732 €



# cooking

chip scuttle / chauffe frite /  
conservador de patatas frite bassin / aquecedor de batatas

# KUSINA®

## 700S SERIES



### General Features

- Stainless steel body
- Easy to clean and hygienic
- Ergonomic design
- Adjustable legs
- Long life



### Caractéristiques Générales

- Corps en acier inoxydable
- Facile à nettoyer, hygiénique
- Conception ergonomique
- Pieds réglables
- Longue durée



### Características Gerais

- Corpo de aço inoxidável
- Higiênica, fácil de limpar
- Design econômico
- Pés ajustáveis
- Longa durabilidade



### Características Generales

- Estructura de acero inoxidable
- Fácil de limpiar, higiénica
- Diseño ergonómico
- Pies ajustables
- Larga vida útil



G7D100E-S

#### PRODCUT HIGHLIGHTING DETAILS

- GN 1/1 Container with oil strainer
- Cupboard with door
- The fried potatoes keep warm by custom porcelain infrared heater
- Removable and easy to clean container

#### DÉTAILS DU PRODUIT

- Bac GN 1/1 avec filtre à huile
- La chaleur est fournie par les radiateurs infrarouges en porcelaine spéciale
- Réservoir du chauffe frite amovible et facile à nettoyer

#### DETALHES DO PRODUTO

- Compartmento para batatas com peneira de óleo GN 1/1
- Gabinete inferior com portas
- Com o aquecimento infravermelho por porcelana especial mantém a temperatura das batatas fritas
- Compartmento de batatas removível e de fácil limpeza

#### DETALLES DEL PRODUCTO

- Cubeta de patatas GN 1/1 con filtro de aceite
- Armario inferior con puertas
- Mantiene caliente a las patatas fritas mediante los calentadores infrarrojos de porcelana especial
- Cubeta desmontable y fácil de limpiar para conservar patatas



Model	Visual	Dim (mm) LxDxH		Power	Gross Weight	Gross Volume	Electrical Inlet	Price
G7D100E-S		400x730x300		0,85 kw	48 kg	0,19 m³	230 V 1N PE	472 €

# cooking

sauce bain marie / bain-marie pour sauce /  
banho-maria para molhos / baño maria

# KUSINA®

## 700S SERIES

CE



### General Features

- Stainless steel body
- Easy to clean and hygienic
- Ergonomic design
- Adjustable legs
- Long life
- Safety Thermostat



### Caractéristiques Générales

- Corps en acier inoxydable
- Facile à nettoyer, hygiénique
- Conception ergonomique
- Pieds réglables
- Longue durée



### Características Gerais

- Corpo de aço inoxidável
- Higiênica, fácil de limpar
- Design econômico
- Pés ajustáveis
- Longa durabilidade
- Válvula de drenagem



### Características Generales

- Estructura de acero inoxidable
- Fácil de limpiar, higiénica
- Diseño ergonómico
- Pies ajustables
- Larga vida útil
- Válvula de alivio



G7S100E-S



G7S200E-S

#### PRODCUT HIGHLIGHTING DETAILS

- The dimensions of the pool are according to the GN Sizes
- Safety thermostat
- Unscratchable and enameled cast iron back grate
- Cupboard with door
- Thermostatic temperature control
- Stainless steel tube heaters under the pool
- Indicator lights when reaching to the required temperature



#### DÉTAILS DU PRODUIT

- Bacs conformes aux dimension de GN
- Cheminée en fonte émaillée inoxydable et anti-rayures
- Contrôle de la température thermostatiques
- Tube de résistance inoxydable sous le bac



#### DETALHES DO PRODUTO

- Compartimento de aquecimento de acordo com as medidas GN
- Chaminé de ferro fundido esmaltado à prova de riscos
- Gabinete inferior com portas
- Controle de aquecimento termostático
- Resistências tubular inoxidável no compartimento inferior

#### DETALLES DEL PRODUCTO

- Cubeta de calentamiento con las dimensiones de GN
- Chimenea de hierro fundido esmaltado inoxidable y no se raya
- Armario inferior con puertas
- Control termostático de temperatura
- Calentadores de tubo bajo de la cubeta

Model	Visual	Dim (mm) LxDxH		Power	Gross Weight	Gross Volume	Electrical Inlet	Tank Capacity	Price
G7S100E-S		400x730x300		1,5 kw	43 kg	0,19 m <sup>3</sup>	230 V 1N PE	GN 1/3 150 mm x 1 GN 2/3 150 mm x 1	592 €
G7S200E-S		800x730x300		3 kw	70 kg	0,36 m <sup>3</sup>	230 V 1N PE	GN 1/1 150 mm x1 GN 1/4 150 mm x3	930 €

# cooking

lavastone griddle / grille de pierre de lave /  
churrasqueira de obsidiana / plancha con piedra volcánica

# KUSINA®

## 700S SERIES



### General Features

- Stainless steel body
- Easy to clean and hygienic
- Ergonomic design
- Adjustable legs
- Long life
- Available lpg or natural gas



### Caractéristiques Générales

- Corps en acier inoxydable
- Facile à nettoyer, hygiénique
- Valve à gaz avec soupape de sécurité
- Conception ergonomique
- Pieds réglables
- Longue durée
- Peut fonctionner au GPL et au gaz naturel



### Características Gerais

- Corpo de aço inoxidável
- Higiênica, fácil de limpar
- Válvula de segurança registro de gás
- Design económico
- Pés ajustáveis
- Longa durabilidade
- Funciona com gás natural e gás GLP



### Características Generales

- Estructura de acero inoxidable
- Fácil de limpiar, higiénica
- Válvula de gas, válvula de seguridad
- Diseño ergonómico
- Pies ajustables
- Larga vida útil
- Adecuada a funcionar con gas natural y el GLP



G7L100G-S



G7L200G-S

#### PRODCUT HIGHLIGHTING DETAILS

- Long life cast iron griddle under the lavstones
- Homogenous cooking surface
- Stainless steel V-shape grilling grate
- Waste oil drawer
- Piezo-electric burner ignition
- Independent two cooking areas of surface
- Insulation to prevent overheating of the body and reduce energy losses
- Slightly sloped cooking surface, easy and convenient for cleaning, with liquid discharge hole

#### DETALHES DO PRODUTO

- Grelha inferior feita em ferro fundido obsidiana de longa durabilidade
- Superfície de cozimento homogênea
- Grelha de aço em forma de "V"
- Compartimento de óleo residual queimador de acendimento piezoelétrico
- Dois compartimentos de cozimento independentes
- Isolamento redutor do nível de perda de aquecimento e aquecimento da área das chapas de metal
- Com uma leve inclinação da superfície de cozimento e orifício para escoamento de líquidos proporcionando uma limpeza fácil e confortável

#### DÉTAILS DU PRODUIT

- Grille inférieur de pierre de lave de longue durée en fonte
- Surface de cuisson homogène
- Tiroir de récupération des graisses en acier inoxydable placé à l'intérieur du placard
- Grille en acier en forme "V"
- Réservoir d'huile usée, brûleur à l'allumage piezoelectrique
- Deux zones de cuisson indépendantes
- L'isolation de l'appareil prévient la perte de chaleur au maximum
- Surface de cuisson en pente douce pour un nettoyage facile et pratique avec trou de décharge de liquide

#### DETALLES DEL PRODUCTO

- Rejilla inferior de piedra volcánica hecha de hierro fundido con larga vida útil
- Superficie homogénea de cocción
- Rejilla de de cocción de acero en forma "V"
- Tanque del aceite usado • Encendido piezoeléctrico del quemador
- Dos zonas de cocción independientes
- Aislamiento que minimiza al calentamiento de las placas en el entorno y minimiza la pérdida de calor
- Superficie de cocción ligeramente inclinada para una limpieza fácil y cómoda con agujero de descarga



Model	Visual	Dim (mm) LxDxH		Power	Gross Weight	Gross Volume	Gas Inlet	Price
G7L100G-S		400x730x300		9 kw	70 kg	0,19 m <sup>3</sup>	R ½ "	693 €
G7L200G-S		800x730x300		18 kw	95 kg	0,36 m <sup>3</sup>	R ½ "	1.145 €

# cooking

neutral unit / élément intermédiaire / bancada para descanso / mesa de soporte

# KUSINA®

## 700S SERIES



### General Features

- Stainless steel body
- Easy to clean and hygienic
- Ergonomic design
- Adjustable legs
- Long life



### Caractéristiques Générales

- Corps en acier inoxydable
- Facile à nettoyer, hygiénique
- Conception ergonomique
- Pieds réglables
- Longue durée



### Características Gerais

- Corpo de aço inoxidável
- Higiênica, fácil de limpar
- Design económico
- Pés ajustáveis
- Longa durabilidade



### Características Generales

- Estructura de acero inoxidable
- Fácil de limpiar, higiénica
- Diseño ergonómico
- Pies ajustables
- Larga vida útil



G7T100N-S



G7T200N-S

#### PRODCUT HIGHLIGHTING DETAILS

- Optional Drawer System
- Unscratchable and enameled cast iron back grate

#### DÉTAILS DU PRODUIT

- La version avec tiroir est optionnelle
- Cheminée en fonte émaillée, inoxydable et anti-rayures



#### DETALHES DO PRODUTO

- Versão com gavetas opcionais
- Chaminé de ferro fundido esmaltado à prova de riscos

#### DETALLES DEL PRODUCTO

- Versión opcional con cajones
- Chimenea de hierro fundido esmaltado inoxidable y no se raya

Model	Visual	Dim (mm) LxDxH		Gross Weight	Gross Volume	Price
G7T100N-S		400x730x300		30 kg	0,19 m <sup>3</sup>	246 €
G7T200N-S		800x730x300		45 kg	0,36 m <sup>3</sup>	295 €



***KUSINA***<sup>®</sup>



**900 SERIES**

# cooking

gas range / cuisinière à gaz / fogão à gás / cocina a gas

# KUSINA®

## 900 SERIES



### General Features

- Stainless steel body
- Easy to clean and hygienic
- Safety gas valve
- Ergonomic design
- Adjustable legs
- Long life
- High efficiency burner
- Insulated oven



### Caractéristiques Générales

- Corps en acier inoxydable
- Facile à nettoyer, hygiénique
- Valve à gaz avec soupape de sécurité
- Conception ergonomique
- Pieds réglables
- Longue durée
- Brûleurs à haut rendement
- Four avec isolation



### Características Gerais

- Corpo de aço inoxidável
- Higiênica, fácil de limpar
- Válvula de segurança registro de gás
- Design econômico
- Pés ajustáveis
- Longa durabilidade
- Queimadores de alta eficiência
- Forno com isolamento



### Características Generales

- Estructura de acero inoxidable
- Fácil de limpiar, higiénica
- Válvula de gas, válvula de seguridad
- Diseño ergonómico
- Pies ajustables
- Larga vida útil
- 2 o 4 fuegos abiertos
- Horno aislado

#### PRODCUT HIGHLIGHTING DETAILS

- 2/4 and 6 Burners , with or without oven
- Easy to clean and simple maintenance with removable burner bottom tray
- Unscratchable and enameled cast iron top grates.
- Nickel coated cast iron burners
- Protected pilot flame
- With oven or cupboards
- Oven available for 2/1 GN trays
- Enamel coated bottom steel sheet
- The body of the oven is made of aluminium coated sheet metal
- Stainless steel double-wall , insulated door
- Self stabilizing flame
- Removable and easy to clean stainless steel oven shelves
- Thermostatic temperature control with safety valve and thermocouple
- Piezo-electric burner ignition

#### DETALHES DO PRODUTO

- 2,4 e 6 queimadores, fácil limpeza e manutenção proporcionadas pelo queimador e bandeja inferior removíveis
- Chaminé e grelha do fogão de ferro fundido esmaltado à prova de riscos de fácil limpeza
- Bocas de ferro fundido niquelado
- Chama-piloto protegido com forno ou com gabinete inferior
- Medida GN 2/1 apropriada para o interior do forno
- Chapa do fundo do forno esmaltada
- Chapa do corpo do forno feita de alumínio
- Porta isolante com parede dupla feita de aço inoxidável estabilizador de chama
- Prateleiras do forno em aço inoxidável removíveis de fácil limpeza
- 2, 4 e 6 queimadores (bocas), modelos com e sem forno
- Forno com prateleiras em aço inoxidável removíveis de fácil limpeza

#### DÉTAILS DU PRODUIT

- 2,4 et 6 brûleurs, plateau inférieur du brûleur amovible, permettant un nettoyage facile, l'entretien et la réparation
- Cheminée et grille supérieur émaillée, en fonte, anti-rayures, faciles à nettoyer.
- Les fours sont en fonte nickelée. Lampe-témoin protégée.
- Fourneau ou armoire inférieure- l'intérieur du fourneau est conforme à la dimension GN 2/1
- Le tôle du plancher du four est en acier émaillé - corps du four
- Fabriqué en tôle revêtue d'aluminium
- La porte est en acier inoxydable, isolée à double membranes avec lampe témoin stabilisée, les grilles sont en acier inoxydables amovibles et faciles à nettoyer
- Robinet à gaz avec vanne thermostatique de sécurité de réglage de la température
- Veilleuse du four de l'allumage piézoélectrique

#### DETALLES DEL PRODUCTO

- Recipiente inferior extraíble de quemador con 2.4 y 6 fuegos abiertos, facil que limpieza, mantenimiento y reparación
- Chimenea y rejilla superior de hierro fundido con recubrimiento de esmalte que se puede limpiar fácilmente y no se raya
- Quemadores niquelados de hierro fundido
- Llama piloto con protección
- Con horno o armario inferior
- Dimensiones interiores del horno están de acuerdo con GN 2/1
- Placa de fondo de hierro esmaltado del horno
- Estructura de horno hecho de placa recubierta con aluminio
- Puerta aislada de doble pared de acero inoxidable
- Llama estabilizada de la luz piloto del horno
- Estantes de horno de acero inoxidable que son extraíbles y fáciles de limpiar
- Válvula termostático de gas con válvula de seguridad, temperatura ajustable
- Encendedor de horno con piloto piezoeléctrico.



# cooking

gas range / cuisinière à gaz / fogão à gás / cocina a gas

# KUSINA®

## 900 SERIES

CE



G9K100G



G9K200G



G9K201G



G9K210G



G9K211G



G9K212G



020.02.04.250



020.03.10.052



020.03.10.056



9RC100G  
reduction

Model	Visual	Dim (mm) LxDxH	Burners kW	Power	Gross Weight	Gross Volume	Gas Inlet	Tray Dimensions	Oven	Price	
G9K100G		400x900x900	2x8,5		17,5 kw	65 kg	0,55 m <sup>3</sup>	R ½ "	-	1.053 €	
G9K200G		800x900x900	4x8,5		35 kw	110 kg	1,05 m <sup>3</sup>	R ½ "	-	1.625 €	
G9K201G		1200x900x900	6x8,5		52,5 kw	152 kg	1,52 m <sup>3</sup>	R ½ "	-	2.081 €	
G9K210G		800x900x900	4x8,5		41 kw	145 kg	1,05 m <sup>3</sup>	R ½ "	GN 2/1x2	6	2.179 €
G9K211G		1200x900x900	6x8,5		58,5 kw	210 kg	1,52 m <sup>3</sup>	R ½ "	GN 2/1x2	6	2.800 €
G9K212G		1200x900x900	6x8,5		63 kw	212 kg	1,60 m <sup>3</sup>	R ½ "	-	10	2.991 €



# cooking

electrical range / cusinière électrique / fogão elétrico / cocina eléctrica

# KUSINA®

## 900 SERIES



### General Features

- Stainless steel body
- Easy to clean and hygienic
- Ergonomic design
- Adjustable legs
- Long life
- Insulated oven



### Caractéristiques Générales

- Corps en acier inoxydable
- Facile à nettoyer, hygiénique
- Valve à gaz avec soupape de sécurité
- Conception ergonomique
- Pieds réglables
- Longue durée
- Four avec isolation



### Características Gerais

- Corpo de aço inoxidável
- Higiênica, fácil de limpar
- Design econômico
- Pés ajustáveis
- Longa durabilidade
- Forno com isolamento



### Características Generales

- Estructura de acero inoxidable
- Fácil de limpiar, higiénica
- Diseño ergonómico
- Pies ajustables
- Larga vida útil
- Horno aislado



G9K100E



G9K200E



G9K210E

#### PRODCUT HIGHLIGHTING DETAILS

- 2 or 4 heating plates, with or without oven models
- Unscratchable enameled cast iron back grate
- 300x300 fast heating square plates
- With oven or cupboards
- Oven available for 2/1 GN trays
- Enamel coated bottom steel sheet
- The body of the oven is made of aluminum coated sheet metal
- Stainless steel double-wall, insulated door
- Stainless steel tube heaters
- Adjustable thermostatic temperature control
- Indicator lights when reaching to the required temperature

#### DÉTAILS DU PRODUIT

- Modèles de 2 et 4 plaques chauffantes, avec four ou sans four
- Cheminée en fonte émaillée inoxydable et anti-rayures
- Plaques carrées 300x300 chauffent rapidement
- Fourneau ou armoire inférieur- l'intérieur du fourneau est conforme à dimension GN 2/1
- La tôle du plancher du four est en acier émaillé
- Signal optique on-off à l'atteint de la température désirée
- Corps du four en tôle revêtu d'aluminium
- La porte en acier inoxydable isolée à double membranes.
- Chauffe-tuyau inoxydable
- Contrôle de la température de thermostat réglable
- Signal optique à l'atteinte de la température désirée



#### DETALHES DO PRODUTO

- Aquecedor com 2 ou 4 placas, modelos com ou sem forno, bandejas de forno
- Chaminé de ferro fundido esmaltado à prova de riscos
- 300 x 300 placas quadradas de aquecimento rápido
- Com forno ou com gabinete inferior
- medida GN 2/1 apropriada para o interior do forno
- Chapa do fundo do forno esmaltada
- Luzes de aviso liga/desliga ao atingir a temperatura desejada
- corpo do forno feito de chapa revestida de alumínio
- Porta isolada com paredes feitas de aço inoxidável
- Resistência tubular inoxidável
- Controle ajustável de temperatura termostático
- Luzes de aviso ao atingir a temperatura desejada

#### DETALLES DEL PRODUCTO

- Modelos con 2,4 placas calientes, con/sin horno
- Chimenea de hierro fundido esmaltado que es inoxidable y no se raya
- Placas calientes de calentamiento rápido en forma cuadrada de 300x300 placas
- Con horno o armario inferior
- Dimensiones interiores del horno están de acuerdo con GN 2/1
- Placa de fondo de hierro esmaltado del horno
- Luces de apagado - encendido cuando alcanza la temperatura deseada
- Estructura de horno hecho de placa recubierta con aluminio
- Puerta aislada de doble pared de acero inoxidable
- Calentadores de tubos de acero inoxidable
- Control termostático con temperatura ajustable
- Luces de advertencia cuando se alcanza la temperatura deseada

Model	Visual	Dim (mm) LxDxH	kW	Plates kW	Power	Gross Weight	Gross Volume	Electrical Inlet	Tray Dimensions	Oven	Price
G9K100E		400x900x900	2x3		6 kw	85 kg	0,59 m³	400 V 3N PE	-	-	1.137 €
G9K200E		800x900x900	4x3		12 kw	130 kg	1,05 m³	400 V 3N PE	-	-	1.775 €
G9K210E		800x900x900	4x3		18 kw	170 kg	1,05 m³	400 V 3N PE	GN 2/1x2	6	2.492 €

# cooking

pasta cooker / cuiseur à pâte /  
macaroni cozedor de massas / cocedor de pasta

# KUSINA®

## 900 SERIES



### General Features

- Stainless steel body
- Easy to clean and hygienic
- Safety Thermostat
- Ergonomic design
- Adjustable legs
- Long life
- Single or double cooking containers



### Caractéristiques Générales

- Corps en acier inoxydable
- Facile à nettoyer, hygiénique
- Valve à gaz avec thermostat de sécurité
- Conception ergonomique
- Pieds réglables
- Longue durée
- 1 et 2 bacs



### Características Gerais

- Corpo de aço inoxidável
- Higiênica, fácil de limpar
- Termostato de segurança
- Design econômico
- Pés ajustáveis
- Longa durabilidade
- Compartimento Simples ou Duplo



### Características Generales

- Estructura de acero inoxidable
- Fácil de limpiar, higiénica
- Diseño ergonómico
- Pies ajustables
- Larga vida útil
- Cubierta Simple y Doble



G9M100E



G9M100G



G9M200E



#### PRODUCT HIGHLIGHTING DETAILS

- Working and safety thermostatic temperature control
- On-off switch with lights when reaching to the required temperature.
- Cooking container with overflow drain
- Stainless steel tube heaters
- Indicator lights when reaching to the required temperature
- Operating temperature range (0-120 °C)

#### DETALHES DO PRODUTO

- Controle de funcionamento e segurança termostático
- Luzes indicadoras de liga/desliga ao atingir aquecimento
- Compartimento com escoamento
- Aquecedor tubular de aço inoxidável
- Luzes de aviso ao atingir a temperatura desejada
- Válvula de segurança registro de gás
- Faixa de temperatura operacional (0-120°C)

#### DÉTAILS DU PRODUIT

- Contrôle de la température de thermostat de fonctionnement et de sécurité
- Lumière on-off à l'atteint de la température
- Bac de trop-plein lié au tuyau d'évacuation
- Chauffage du tube en acier inoxydable
- Signal optique à l'atteint de la température désirée
- Plage de température de fonctionnement (0-120 °C)

#### DETALLES DEL PRODUCTO

- Control de la temperatura con termostato de funcionamiento y termostato de seguridad
- Luces de apagado - encendido cuando alcanza la temperatura deseada
- Cubeta con desagüe con rebosadero de desagüe
- Calentador de tubo de acero inoxidable
- Luces de advertencia cuando se alcanza la temperatura deseada
- Válvula de gas, válvula de seguridad
- Rango de la temperatura de funcionamiento (0-120 °C)



Basket Combination

Model	Visual	Dim (mm) LxDxH		Power	Gross Weight	Gross Volume	Electrical Inlet	Gas Inlet	Capacity (lt)	Basket Size	Price
G9M100E		400x900x900		12 kw	45 kg	0,56 m³	400 V 3N PE	-	30 lt	145x270x180 (2pcs) 135x135x180 (2pcs)	1.293 €
G9M100G		400x900x900		10 kw	86 kg	0,55 m³	-	R ½"	35 lt	115x160x255 (2pcs) 160x237x255 (2pcs)	1.418 €
G9M200E		800x900x900		24 kw	83 kg	0,56 m³	400 V 3N PE	-	2x30 lt	145x270x180 (4pcs) 135x135x180 (4pcs)	2.045 €

# cooking

fry top / grille / churrasqueira / plancha

# KUSINA®

## 900 SERIES



### General Features

- Stainless steel body
- Easy to clean and hygienic
- Ergonomic design
- Adjustable legs
- Long life
- High efficiency burner
- Available LPG or natural gas



### Caractéristiques Générales

- Corps en acier inoxydable
- Facile à nettoyer, hygiénique
- Valve à gaz avec soupape de sécurité
- Conception ergonomique
- Pieds réglables
- Longue durée
- Brûleurs à haut rendement
- Peut fonctionner au GPL et au gaz naturel



### Características Gerais

- Corpo de aço inoxidável
- Higiênica, fácil de limpar
- Válvula de segurança registro de gás
- Design económico
- Pés ajustáveis
- Longa durabilidade
- Queimadores de alta eficiência
- Funciona com gás natural ou com gás GPL



### Características Generales

- Estructura de acero inoxidable
- Fácil de limpiar, higiénica
- Válvula de gas, válvula de seguridad
- Diseño ergonómico
- Pies ajustables
- Larga vida útil
- 2 o 4 fuegos abiertos
- Puede funcionar con gas natural y GLP



#### PRODUCT HIGHLIGHTING DETAILS

- Smooth, ribbed and ½ smooth + ½ ribbed fry top plates versions
- Fry top with cupboard
- ST 52 steel or hard chromium coated steel 15 mm thick griddle plate
- Cooking surface perimeter is 3 mm thick stainless steel
- Stainless steel oil collection drawer is placed in cupboard
- Slightly sloped cooking surface, easy and convenient for cleaning, with liquid discharge hole.
- Homogenous heated cooking surface
- Special machined grooves
- Waste oil drawer
- Thermostatic temperature control
- Thermocouple safety device connected to the burner
- Piezo-electric burner ignition
- Double independent cooking surface
- Insulation to prevent overheating of the body and reduce energy losses
- Operating temperature range (50-300 °C)

#### DETALHES DO PRODUTO

- Nas versões com superfície de cozimento plana, com ranhuras ou com ranhuras+plana
- Churrasqueira com gabinete inferior com portas
- Churrasqueira com 15 mm de espessura aço st 52 ou revestido de cromo duro aço platinum
- Área da superfície de cozimento em aço inoxidável com espessura de 3mm
- Gaveta coletora de gordura em aço inoxidável localizada dentro do gabinete
- Superfície de cozimento com uma leve inclinação para uma limpeza fácil e confortável
- Orifício para escoamento de líquidos
- Superfície de cozimento com aquecimento homogêneo
- Ranhuras com funcionalidades especiais
- Recipiente de óleo residual
- Controle termostático de temperatura
- Sistema de segurança termopar ligado ao queimador
- Queimadores com acionamento piezoelétrico nas versões com uma ou duas áreas de cozimento independentes
- Isolamento redutor do nível de perda de aquecimento e aquecimento da área das chapas de metal
- Queimadores com acionamento piezoelétrico duas áreas de cozimento independentes
- Orifício para escoamento de líquidos
- Isolamento redutor do aquecimento da área das chapas e perda de temperatura
- Faixa de temperatura operacional (50 -300°C)

#### DÉTAILS DU PRODUIT

- Versions lisse, nervurée et mixte de la surface de cuisson
- Armoires avec portes sous le grille
- Les grilles sont soit acier ST 52 de 15 mm d'épaisseur soit en acier et chromé dur
- Le pourtour de surface de cuisson est en acier inoxydable de 3mm d'épaisseur
- Tiroir de récupération des graisses en acier inoxydable placé à l'intérieur du placard
- Surface de cuisson en pente douce pour le nettoyage facile et pratique
- Trou de décharge du liquide - surface de cuisson avec chauffe homogène
- Rainures avec traitement spécial - Réservoir d'huile usée
- Contrôle de la température thermostatique
- Un système de sécurité à thermocouple est lié au brûleur
- Brûleur à l'allumage piézoélectrique avec versions à une ou deux zones de cuissons indépendantes
- L'isolation de l'appareil prévient la perte de chaleur au maximum
- Brûleur à l'allumage piézoélectrique à deux zones de cuissons indépendantes
- Plage de température de fonctionnement (50-300 °C)

#### DETALLES DEL PRODUCTO

- Versiones de la superficie de cocción son plana, acanalada o acanalada
- Armario con puertas en la parte inferior de la plancha
- Rejillas de acero platina cromadas con cromo duro o acero de st 52 con espesor de 15 mm
- Entorno de la superficie de cocción es de acero inoxidable de 3 mm de espesor
- Cajón de recogida de grasas de acero inoxidable colocado dentro del armario
- Superficie de cocción ligeramente inclinada para una limpieza fácil y cómoda
- Orificio de drenaje de líquido
- Superficie de cocción que ofrece una cocción homogénea
- Ranuras procesadas especialmente
- Tanque del aceite usado
- Control termostático de la temperatura
- El sistema de seguridad con termopar conectado al quemador
- Versiones de zonas de cocción con una o dos zonas independientes y con quemados de encendido piezoeléctrico
- Aislamiento que minimiza al calentamiento de las placas en el entorno y minimiza la pérdida de calor
- Dos zonas de cocción con quemados de encendido piezoeléctrico
- Orificio de drenaje de líquido
- Rango de la temperatura de funcionamiento (50-300 °C)

# cooking

fry top / grille / churrasqueira / plancha

# KUSINA®

## 900 SERIES

CE



G9I200E



G9I210E



G9I220E



G9I200G



G9I210G



G9I220G



G9I100E



G9I110E



G9I100G



G9I110G

Model	Visual	Dim (mm) LxDxH		Power	Gross Weight	Gross Volume	Gas Inlet	Electrical Inlet	Smooth	Ribbed	Price
G9I200E		800x900x900		12 kw	165 kg	1,05 m <sup>3</sup>	-	400 V 3N PE	✓		1.612 €
G9I210E		800x900x900		12 kw	165 kg	1,05 m <sup>3</sup>	-	400 V 3N PE		✓	1.862 €
G9I220E		800x900x900		12 kw	165 kg	1,05 m <sup>3</sup>	-	400 V 3N PE	✓	✓	1.786 €
G9I200G		800x900x900		18 kw	152 kg	1,05 m <sup>3</sup>	R ½ "	-	✓		1.505 €
G9I210G		800x900x900		18 kw	126 kg	0,90 m <sup>3</sup>	R ½ "	-		✓	1.794 €
G9I220G		800x900x900		18 kw	126 kg	0,90 m <sup>3</sup>	R ½ "	-	✓	✓	1.647 €
G9I100E		400x900x900		6 kw	60 kg	0,56 m <sup>3</sup>	-	400 V 3N PE	✓		1.086 €
G9I110E		400x900x900		6 kw	90 kg	0,56 m <sup>3</sup>	-	400 V 3N PE	-	✓	1.328 €
G9I100G		400x900x900		9 kw	87 kg	0,55 m <sup>3</sup>	R ½ "	-	✓	-	1.053 €
G9I110G		400x900x900		9 kw	87 kg	0,55 m <sup>3</sup>	R ½ "	-		✓	1,265 €

# cooking chrome plated

fry top / grille / churrasqueira / plancha

# KUSINA®

## 900 SERIES



G9I200E-C



G9I210E-C



G9I220E-C



G9I200G-C



G9I210G-C



G9I220G-C



G9I100E-C



G9I110E-C



G9I100G-C



G9I110G-C

Model	Visual	Dim (mm) LxDxH		Power	Gross Weight	Gross Volume	Gas Inlet	Electrical Inlet	Smooth	Ribbed	Price
G9I200E-C		800x900x900		12 kw	150 kg	1,05 m <sup>3</sup>	-	400 V 3N PE	✓		2.144 €
G9I210E-C		800x900x900		12 kw	150 kg	1,05 m <sup>3</sup>	-	400 V 3N PE		✓	2.394 €
G9I220E-C		800x900x900		12 kw	150 kg	1,05 m <sup>3</sup>	-	400 V 3N PE	✓	✓	2.318 €
G9I200G-C		800x900x900		18 kw	152 kg	1,05 m <sup>3</sup>	R ½ "	-	✓		2.037 €
G9I210G-C		800x900x900		18 kw	126 kg	0,90 m <sup>3</sup>	R ½ "	-		✓	2.326 €
G9I220G-C		800x900x900		18 kw	126 kg	0,90 m <sup>3</sup>	R ½ "	-	✓	✓	2.179 €
G9I100E-C		400x900x900		6 kw	60 kg	0,56 m <sup>3</sup>	-	400 V 3N PE	✓		1.441 €
G9I110E-C		400x900x900		6 kw	65 kg	0,56 m <sup>3</sup>	-	400 V 3N PE	-	✓	1.684 €
G9I100G-C		400x900x900		9 kw	87 kg	0,55 m <sup>3</sup>	R ½ "	-	✓	-	1.408 €
G9I110G-C		400x900x900		9 kw	87 kg	0,55 m <sup>3</sup>	R ½ "	-		✓	1,621 €

# cooking

fryer / friteuse / fritadeira / freidora

# KUSINA®

## 900 SERIES



### General Features

- Stainless steel body
- Easy to clean and hygienic
- Ergonomic design
- Adjustable legs
- Long life
- Monoblock bowl
- Safety gas valve
- Safety thermostat



### Caractéristiques Générales

- Corps en acier inoxydable
- Facile à nettoyer, hygiénique
- Conception ergonomique
- Pieds réglables
- Longue durée
- Corps monobloc
- Valve à gaz avec soupape de sécurité
- Thermostat de sécurité
- Différentes capacités sont disponibles



### Características Gerais

- Corpo de aço inoxidável
- Higiênica, fácil de limpar
- Design económico
- Pés ajustáveis
- Longa durabilidade
- Corpo monobloco
- Válvula de segurança registro de gás
- Termostato de segurança
- Disponível em diferentes capacidades



### Características Generales

- Estructura de acero inoxidable
- Fácil de limpiar, higiénica
- Diseño ergonómico
- Pies ajustables
- Larga vida útil
- Estructura monobloque
- Válvula de gas ,válvula de seguridad
- Termostato de seguridad

#### PRODCUT HIGHLIGHTING DETAILS

- Single or double container models
- Unscratchable and stainless enameled cast back grate
- Fryer with cupboard
- Piezo-electric burner ignition
- Thermostatic temperature control
- Stainless steel baskets
- Adjustable temperature
- High efficient gas combustion system
- Operating temperature range (0-180 °C)

#### DETALHES DO PRODUTO

- Nas versões com compartimento simples ou duplo
- Chaminé de ferro fundido esmaltado à prova de riscos
- Gabinete inferior com portas
- Queimador de ignição piezoelétrico
- Controle de temperatura termostático
- Cestos inoxidáveis
- Temperatura de aquecimento ajustável
- Sistema de combustão à gás que proporciona alta eficiência
- Faixa de temperatura operacional (0-180°C)

#### DÉTAILS DU PRODUIT

- Modèles avec 1 ou 2 bacs
- Cheminée en fonte émaillé inoxydable et anti-rayures
- Armoire inférieure avec porte
- Brûleur à l'allumage piézoélectrique
- Contrôle de la température du thermostat
- Paniers en acier inoxydable
- Température réglable
- Système de combustion de gaz à grande efficacité
- Plage de température de fonctionnement (0-180 °C)

#### DETALLES DEL PRODUCTO

- Versiones de simple o doble cubetas
- Chimenea de hierro fundido esmaltado inoxidable y no se raya
- Armario inferior con puertas
- Encendido piezoeléctrico del quemador
- Control termostático de temperatura
- Cestas inoxidables
- Temperatura ajustable
- Sistema de quema de gas de alta eficiencia
- Rango de la temperatura de funcionamiento (0-180 °C)



G9F100E



G9F200E



G9F100G



G9F200G

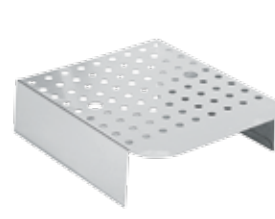
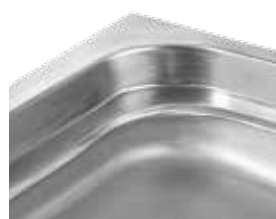

Model	Visual	Dim (mm) LxDxH		Power	Gross Weight	Gross Volume	Gas Inlet	Electrical Inlet	Basket Size	Capacity	Price
G9F100E		400x900x900		18 kw	65 kg	0,56 m <sup>3</sup>	-	400 V 3N PE	140x350x170	24 lt	1.347 €
G9F200E		800x900x900		36 kw	110 kg	1,05 m <sup>3</sup>	-	400 V 3N PE	140x350x170	2x24 lt	2.072 €
G9F100G		400x900x900		18 kw	72 kg	0,55 m <sup>3</sup>	R 1/2"	-	140x350x130	22 lt	1.582 €
G9F200G		800x900x900		36 kw	123 kg	1,05 m <sup>3</sup>	R 1/2"	-	140x350x130	2x22 lt	2.629 €

# cooking

tilting bratt pan / sauteuse basculantet /  
frigideira basculante / sartén basculante

# KUSINA®

## 900 SERIES



### General Features

- Stainless steel body
- Easy to clean and hygienic
- Ergonomic design
- Adjustable legs
- Long life



### Caractéristiques Générales

- Corps en acier inoxydable
- Facile à nettoyer, hygiénique
- Conception ergonomique
- Pieds réglables
- Longue durée
- Corps monobloc
- Valve à gaz avec sopapae de sécurité
- Thermostat de sécurité
- Différentes capacités sont disponibles



### Características Gerais

- Corpo de aço inoxidável
- Higiênica, fácil de limpar
- Design económico
- Pés ajustáveis
- Longa durabilidade



### Características Generales

- Estructura de acero inoxidable
- Fácil de limpiar, higiénica
- Diseño ergonómico
- Pies ajustables
- Larga vida útil

#### PRODCUT HIGHLIGHTING DETAILS

- Stainless steel cooking pan
- While tilting bratt pan switch step in, system stops
- Safety thermostat
- Capacity with 80 lt and 120 lt
- Self hinged lid
- 200 mm Depth stainless steel pan
- Unscratchable enameled cast iron back grate
- Thermostatic temperature control
- Tubular burner placed under the tank
- Pilot light and valve with thermocouple
- Adjustable heating system 50°C - 300°C
- \* Piezo-electric burner ignition
- \* Hand-wheel boost system
- \* Water filling pipe controlled from front panel

#### DETALHES DO PRODUTO

- Caldeira inoxidável
- Botão de segurança para interrupção de funcionamento quando a caldeira é removida
- Termostato de segurança nas versões de 80 e 120 litros
- Tampa autoarticulada compartimento inoxidável com profundidade de 200 mm
- Chaminé de ferro fundido esmaltado à prova de riscos
- Controle de temperatura termostático
- Aquecedores tubulares inoxidáveis sob o compartimento de cozimento
- Temperatura ajustável, 50 °C - 300 °C
- Luzes de aviso ao atingir a temperatura desejada
- Elevação manual com volante
- Tubo de enchimento de água, controlado a partir de painel frontal
- Válvula de segurança registro de gás

#### DÉTAILS DU PRODUIT

- Chaudière inoxydable
- Interrupteur de sécurité arrêt de travail avec le retrait de la chaudière
- Thermostat de sécurité
- Cuve en acier inoxydable pivotante sur soi avec profondeur de la cuve 200 mm
- Cheminée en fonte émaillée inoxydable et anti-rayures
- Contrôle de la température du thermostat
- Tuyaux de chauffe inoxydables sous la cuve de cuisson
- Température réglable de 50°C à 300°C
- Signal optique à l'atteint de la température désirée
- Volant manuel
- Chargeur d'eau contrôlé par le panneau avant

#### DETALLES DEL PRODUCTO

- caldera inoxidable
- Interruptor de seguridad que para el funcionamiento cuando se retira la caldera de cocción
- Versiones del termostato de seguridad con 80 y 120 litros
- Profundidad de la cubeta de acero inoxidable con cubierta bisagrada es de 200 mm
- Chimenea de hierro fundido esmaltado que es inoxidable y no se raya
- Control termostático de temperatura
- Calentadores con tubos de acero inoxidable bajo la cubeta de cocción
- Temperatura ajustable a 50 °C - 300 °C
- Luces de advertencia cuando se alcanza la temperatura deseada
- Inclinación manual con manija
- Tubo de llenado de agua controlado desde el panel frontal



G9TD200E



G9TD200G



G9TD201E



G9TD201G



Model	Visual	Dim (mm) LxDxH		Power	Gross Weight	Gross Volume	Gas Inlet	Electrical Inlet	Capacity	Price
G9TD200E		800x900x900		12 kw	150 kg	1,05 m <sup>3</sup>	-	400 V 3N PE	80 lt	3.414 €
G9TD200G		800x900x900		20 kw	175 kg	1,05 m <sup>3</sup>	R 1/2"	230V 1N PE	80 lt	3.403 €
G9TD201E		1200x900x900		18 kw	185 kg	1,52 m <sup>3</sup>	-	400 V 3N PE	120 lt	4.463 €
G9TD201G		1200x900x900		30 kw	185 kg	1,52 m <sup>3</sup>	R 1/2"	230V 1N PE	120 lt	4.212 €

# cooking

boiling pan / marmite / panela para ferver / marmita

# KUSINA®

## 900 SERIES

CE



### General Features

- Stainless steel body
- Easy to clean and hygienic
- Ergonomic design
- Adjustable legs
- Long life



### Caractéristiques Générales

- Corps en acier inoxydable
- Facile à nettoyer, hygiénique
- Conception ergonomique
- Pieds réglables
- Longue durée



### Características Gerais

- Corpo de aço inoxidável
- Higiênica, fácil de limpar
- Design econômico
- Pés ajustáveis
- Longa durabilidade



### Características Generales

- Estructura de acero inoxidable
- Fácil de limpiar, higiénica
- Diseño ergonómico
- Pies ajustables
- Larga vida útil



G9KT200G



G9KT201G



G9KT200E



G9KT201E

#### PRODCUT HIGHLIGHTING DETAILS

- Water inlet tap and a drain tap on the
- Direct or indirect heating
- High efficiency by using oil in jacket
- Long life and minimum maintenance provided by using oil in jacket
- Safety thermostat
- Safety discharge valve
- Operating temperature range (0-180 °C)

#### DÉTAILS DU PRODUIT

- Robinet de remplissage d'eau et valve de vidange
- Chauffage direct ou indirect
- Chauffage indirect avec huileuse fournissant une grande efficacité
- Longue durée avec un entretien minimum grâce à l'huile utilisée dans les vestes
- Thermostat de sécurité
- Valve à gaz avec sopapae de sécurité
- Contrôle thermostatique
- Plage de température de fonctionnement (0-180 °C)

#### DETALHES DO PRODUTO

- Torneira para encher d'água e válvula de drenagem
- Aquecimento direto ou indireto
- Alta eficiência proporcionada pelo aquecimento indireto do óleo
- Graças ao óleo que é usado entre as jaquetas tem longa duração e baixa manutenção
- Termostato de segurança
- Válvula de segurança registro de gás
- Controle termostático
- Faixa de temperatura operacional (0-180°C)

#### DETALLES DEL PRODUCTO

- Grifo de llenado de agua y válvula de drenaje
- Calentamiento directo o indirecto
- Calentamiento indirecto con aceite que proporciona una alta eficiencia
- Una larga vida útil con mantenimiento mínimo como resultado del aceite utilizado entre las chaquetas
- Termostato de seguridad
- Válvula de gas ,válvula de seguridad
- Control termostático
- Rango de la temperatura de funcionamiento (0-180 °C)



Model	Visual	Dim (mm) LxDxH		Power	Gross Weight	Gross Volume	Gas Inlet	Electrical Inlet	Capacity	Price
G9KT200G		800x900x900		20 kw	185 kg	1,05 m <sup>3</sup>	R ½"	230V 1 N PE	150 lt	3.853,€
G9KT201G		1200x900x900		30 kw	210 kg	1,52 m <sup>3</sup>	R ½"	230V 1N PE	250 lt	4.651 €
G9KT200E		800x900x900		12 kw	180 kg	1,05 m <sup>3</sup>	-	400 V 3N PE	150 lt	3.962 €
G9KT201E		1200x900x900		24 kw	210 kg	1,37 m <sup>3</sup>	-	400 V 3N PE	250 lt	4.935 €



# cooking

sauce bain marie / bain-marie pour sauce /  
banho-maria para molhos / baño maria

# KUSINA®

## 900 SERIES



### General Features

- Stainless steel body
- Easy to clean and hygienic
- Ergonomic design
- Adjustable legs
- Long life
- Safety Thermostat
- Water drainage top



### Caractéristiques Générales

- Corps en acier inoxydable
- Facile à nettoyer, hygiénique
- Conception ergonomique
- Pieds réglables
- Longue durée
- Thermostat de sécurité
- Soupape de purge



### Características Gerais

- Corpo de aço inoxidável
- Higiênica, fácil de limpar
- Design econômico
- Pés ajustáveis
- Longa durabilidade
- Termostato de segurança
- válvula de drenagem



### Características Generales

- Estructura de acero inoxidable
- Fácil de limpiar, higiénica
- Diseño ergonómico
- Pies ajustables
- Larga vida útil
- Termostato de seguridad
- Válvula de alivio



G9S100E



G9S200E

#### PRODUCT HIGHLIGHTING DETAILS

- The dimensions of the pool are according to the GN Sizes
- Safety thermostat
- Unscratchable and enameled cast iron back grate
- Cupboard with door
- Thermostatic temperature control
- Stainless steel tube heaters under the pool
- Indicator lights when reaching to the required temperature
- Operating temperature range (30-90 °C)

#### DÉTAILS DU PRODUIT

- Bacs conformes aux dimensions de GN
- Thermostat de sécurité
- Cheminée en fonte émaillée inoxydable et anti-rayures
- Armoire inférieure à porte
- Contrôle de la température thermostatique
- Tube de résistance inoxydable sous le bac
- Signal optique à l'atteinte de la température désirée
- Plage de température de fonctionnement (30-90 °C)

#### DETALHES DO PRODUTO

- Compartimento de aquecimento de acordo com as medidas GN
- Termostato de segurança
- Chaminé de ferro fundido esmaltado à prova de riscos
- Gabinete inferior com portas
- Controle de aquecimento termostático
- Resistências tubular inoxidável no compartimento inferior
- Luzes de aviso ao atingir a temperatura desejada
- Faixa de temperatura operacional (30 -90°C)

#### DETALLES DEL PRODUCTO

- Cubeta de calentamiento con las dimensiones de GN
- Termostato de seguridad
- Chimenea de hierro fundido esmaltado inoxidable y no se raya
- Armario inferior con puertas
- Control termostático de temperatura
- Calentadores de tubo bajo de la cubeta
- Luces de advertencia cuando se alcanza la temperatura deseada
- Rango de la temperatura de funcionamiento (30-90 °C)



Model	Visual	Dim (mm) LxDxH		Power	Gross Weight	Gross Volume	Electrical Inlet	Tank Capacity	Price
G9S100E		400x900x900		2 kw	65 kg	0,56 m³	230 V 1N PE	150 mm GN 1/1x1 150 mm GN 1/3x1	837 €
G9S200E		800x900x900		4 kw	85 kg	1,05 m³	230 V 1N PE	150 mm GN 1/1x2 150 mm GN 1/3x2	1.058 €

# cooking

lavastone griddle / grille de pierre de lave /  
churrasqueira de obsidiana / plancha con piedra volcánica

# KUSINA®

## 900 SERIES



### General Features

- Stainless steel body
- Easy to clean and hygienic
- Ergonomic design
- Adjustable legs
- Long life



### Caractéristiques Générales

- Corps en acier inoxydable
- Facile à nettoyer, hygiénique
- Valve à gav avec soupape de sécurité
- Conception ergonomique
- Pieds réglables
- Longue durée



### Características Gerais

- Corpo de aço inoxidável
- Higiênica, fácil de limpar
- Válvula de segurança registro de gás
- Design econômico
- Pés ajustáveis
- Longa durabilidade



### Características Generales

- Estructura de acero inoxidable
- Fácil de limpiar, higiénica
- Válvula de gas, válvula de seguridad
- Diseño ergonómico
- Pies ajustables
- Larga vida útil



G9L100G



G9L200G

#### PRODCUT HIGHLIGHTING DETAILS

- Long life cast iron griddle under the lavstones
- Homogenous cooking surface
- Stainless steel oil collection drawer is placed in cupboard
- Stainless steel V-shape grilling grate
- Waste oil drawer
- Piezo-electric burner ignition
- Independent two cooking areas of surface
- Insulation to prevent overheating of the body and reduce energy losses
- Slightly sloped cooking surface, easy and convenient for cleaning, with liquid discharge hole

#### DETALLES DEL PRODUCTO

- Rejilla inferior de piedra volcánica hecha de hierro fundido con larga vida útil
- Superficie homogénea de cocción
- Cajón de recogida de grasas de acero inoxidable colocado dentro del armario
- Rejilla de cocción de acero en forma "v"
- Tanque del aceite usado • Encendido piezoeléctrico del quemador
- Dos zonas de cocción independientes
- Aislamiento que minimiza al calentamiento de las placas en el entorno y minimiza la pérdida de calor
- Superficie de cocción ligeramente inclinada para una limpieza fácil y cómoda con agujero de descarga

#### DÉTAILS DU PRODUIT

- Grille inférieure de pierre de lave de longue durée en fonte
- Surface de cuisson homogène
- Tiroir de récupération des graisses en acier inoxydable placé à l'intérieur du placard
- Grille en acier sous forme "v"
- Réservoir d'huile usée, brûleur à l'allumage piézoélectrique
- Deux zones de cuisson indépendantes
- L'isolation del l'appareil prévient la perte de chaleur au maximum
- Surface de cuisson en pente douce pour un nettoyage facile et pratique avec trou de décharge de liquide

#### DETALHES DO PRODUTO

- Grelha inferior feita em ferro fundido obsidiana de longa durabilidade
- Superfície de cozimento homogêneo
- Gaveta coletora de gordura em aço inoxidável localizada dentro do gabinete
- Grelha em aço
- Compartimento de óleo residual queimador de acendimento piezoelétrico
- Duas áreas de cozimento independentes
- Isolamento redutor do nível de perda de aquecimento e aquecimento da área das chapas de metal
- Com uma leve inclinação da superfície de cozimento e orifício para escoamento de líquidos proporcionando uma limpeza fácil e confortável



Model	Visual	Dim (mm) LxDxH		Power	Gross Weight	Gross Volume	Gas Inlet	Price
G9L100G		400x900x900		11 kw	89 kg	0,55 m <sup>3</sup>	R ½"	1.077 €
G9L200G		800x900x900		22 kw	154 kg	1,05 m <sup>3</sup>	R ½"	1.620 €

# cooking

neutral unit / élément intermédiaire / bancada para descanso / mesa de soporte

# KUSINA®

## 900 SERIES

CE



### General Features

- Stainless steel body
- Easy to clean and hygienic
- Ergonomic design
- Adjustable legs
- Long life



### Caractéristiques Générales

- Corps en acier inoxydable
- Facile à nettoyer, hygiénique
- Conception ergonomique
- Pieds réglables
- Longue durée



### Características Gerais

- Corpo de aço inoxidável
- Higiênica, fácil de limpar
- Design económico
- Pés ajustáveis
- Longa durabilidade



### Características Generales

- Estructura de acero inoxidable
- Fácil de limpiar, higiénica
- Diseño ergonómico
- Pies ajustables
- Larga vida útil



G9T100N



G9T200N

#### PRODCUT HIGHLIGHTING DETAILS

- Cupboard with door
- Optional drawer system
- Unscratchable and enameled cast iron back grate



#### DÉTAILS DU PRODUIT

- Armoire inférieure à porte
- La version avec tiroir est optionnelle
- Cheminée en fonte émaillée, inoxydable et anti-rayures

#### DETALHES DO PRODUTO

- Gabinete inferior com portas
- Versão com gavetas opcionais
- Chaminé de ferro fundido esmaltado à prova de riscos



#### DETALLES DEL PRODUCTO

- Armario inferior con puertas
- Versión opcional con cajones
- Chimenea de hierro fundido esmaltado inoxidable y no se raya

Model	Visual	Dim (mm) LxDxH		Gross Weight	Gross Volume	Price
G9T100N		400x900x900		65 kg	0,56 m <sup>3</sup>	469 €
G9T200N		800x900x900		67 kg	1,05 m <sup>3</sup>	568 €

# cooking

charcoal grill / grill à charbon / grelha a carvão / parrilla de carbón

# KUSINA®



## General Features

- Stainless steel body
- Easy to clean and hygienic
- Ergonomic design
- Adjustable legs
- Long life
- Monoblock bowl
- Safety gas valve
- Safety thermostat



## Caractéristiques Générales

- Corps en acier inoxydable
- Facile à nettoyer, hygiénique
- Conception ergonomique
- Pieds réglables
- Longue durée
- Corps monobloc
- Valve à gaz de sécurité
- Thermostat de sécurité



## Características Gerais

- Corpo de aço inoxidável
- Higiênica, fácil de limpar
- Design econômico
- Pés ajustáveis
- Longa durabilidade
- Corpo monobloco
- Válvula de segurança registro de gás
- Termostato de segurança
- Disponível em diferentes capacidades



## Características Generales

- Estructura de acero inoxidable
- Fácil de limpiar, higiénica
- Diseño ergonómico
- Pies ajustables
- Larga vida útil
- Estructura monobloque
- Válvula de gas ,válvula de seguridad
- Termostato de seguridad

### PRODCUT HIGHLIGHTING DETAILS

- Electrostatic black powder coated or stainless frame system
- Stainless steel upper body and lifting system
- Coal combustion chamber paved with firebrick
- Ash scddapping hole in combustion chamber for easy ash collecting
- Cooking platform with removable grates for easy cleaning
- Round rod grate, square rod grate and cast iron grate options for different type of foods
- Removable stainless steel oil tank for easy cleaning
- Optional glass seperators for prevent smell and smoke during cooking
- Optional hood system with or w/o ventilation and filter system

### DÉTAILS DU PRODUIT

- Structure avec poudre noire électrotatique enduite ou en inox
- Structure supérieure et système de levage en acier inoxydable
- Chambre de combustion du charbon pavée de briques réfractaires
- Récipient dans la chambre de combustion pour faciliter la collecte des cendres
- Plate forme de cuisson avec des grilles amovibles pour faciliter le nettoyage
- Grille avec tige ronde, en option grille avec tige carrée et en fonte pour la cuisson de différents types d'aliments
- Réservoir d'huile en acier inoxydable amovible pour un nettoyage facile
- En option, séparateurs en verre pour prévenir contre les odeurs et de la fumée pendant la cuisson
- En option, système de hotte avec ou sans ventilation et filtre

### DETALHES DO PRODUTO

- Estructura higiénica para trabajos duros con el sistema de marco duradero recubierto con pintura negra electrostática en polvo o de acero inoxidable.
- Estructura superior y columnas de elevación de acero inoxidable
- Plataforma parrilla ajustable con el sistema de elevación eléctrica
- Cámara de combustión de carbón recubierta con ladrillos refractarios
- Recipiente de separación de cenizas en la cámara de combustión para facilita la colección de cenizas
- Plataforma de Cocción con rejillas desmontables para facilitar la limpieza
- Rejillas con opciones de varillas redondas, cuadradas y de hierro fundido para diferentes tipos de alimentos
- Tanque de aceite de acero inoxidable extraíble para una limpieza fácil
- Opción de seperador de vidrio para evitar olor y humo durante la cocción
- Sistema de cubierta con o sin sistema de ventilación y filtro

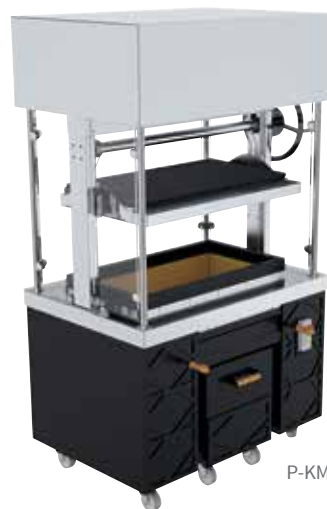

P-KM85HM12

### DETALLES DEL PRODUCTO

- Sistema de estrutura resistente corpo banhado com pó preto eletrostático ou aço inoxidável para tarefas pesadas e higiene adequada
- Parte superior do corpo feita em aço inoxidável e com sistema de elevação
- Sistema de elevação elétrico com plataforma da grelha ajustável
- Área de queima de carvão coberta com tijolos refratários
- Para facilitar o procedimento de coleta das cinzas é encontrada uma fenda coletora na área de queima de carvão
- Plataforma de cozimento com grelhas removíveis para uma fácil limpeza
- Para diferentes tipos de alimento, haste redonda para espeto, haste quadrada para espeto e opções de grelhas em ferro fundido
- Reservatório de gordura removível feito em aço inoxidável para limpeza fácil
- Opção de separador de vidro para bloquear o cheiro e a fumaça durante o cozimento
- Opção com tampa com ou sem sistema de ventilação e filtragem

Specifications	P-KM85HM20	P-KM85HM16	P-KM85HM12
Number of Grate	4	3	2
External Dimensions	2000x850x1784	1600x850x1784	1200x850x1784
Weight / Packed Weight	550 kg. / 630 kg.	420 kg. / 504 kg.	345 kg. / 378 kg.
Motor Energy	220 V / 240 V	220 V / 240 V	220 V / 240 V
Charcoal Capacity per Cycle	37 kg.	29 kg.	22 kg.
Manuel Control			✓
Coal Bin Trolleys (optional)	✓	✓	✓
Stainless Stell Body (optional)	✓	✓	✓
Glass Seperators (optional)	✓	✓	✓
Canapoy With or W/O Fan	✓	✓	✓

# cooking

charcoal grill / grill à charbon / grelha a carvão / parrilla de carbón

# KUSINA



P-KM85HM12



P-KM85HM16

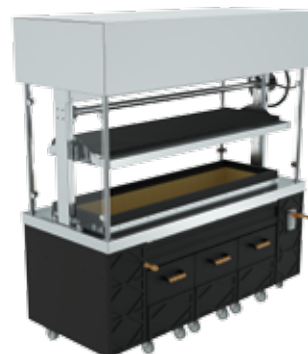

P-KM85HM20

Model	P-KM85HM12	P-KM85HM16	P-KM85HM20
Price	6.055 €	6.845,00 €	7.900 €



## OPTIONAL

CODE	NAME	FEATURES	PRICE
020.02.07.100	Front Glass for 1200 mm	1039x831x10 mm	89 €
020.02.07.101	Front Glass for 1600 mm	1439x831x10 mm	126 €
020.02.07.102	Front Glass for 2000 mm	1839x831x10 mm	158 €
020.02.07.103	Side Glass for All	270x831x10 mm	24 €
851.000.001	Canopy for 1200 mm	1200x850x400 mm	464 €
851.000.002	Canopy for 1600 mm	1600x850x400 mm	540 €
851.000.003	Canopy for 2000 mm	2000x850x400 mm	663 €
010.03.01.320	Glass Holder	850mm ø32 pipe	19 €
040.04.99.005	Round Rod Grate	441x509 mm	302 €
040.04.99.005	Square Rod Grate	441x509 mm	371 €
020.03.02.131	Cast Iron Grate	130x515 mm	70 €

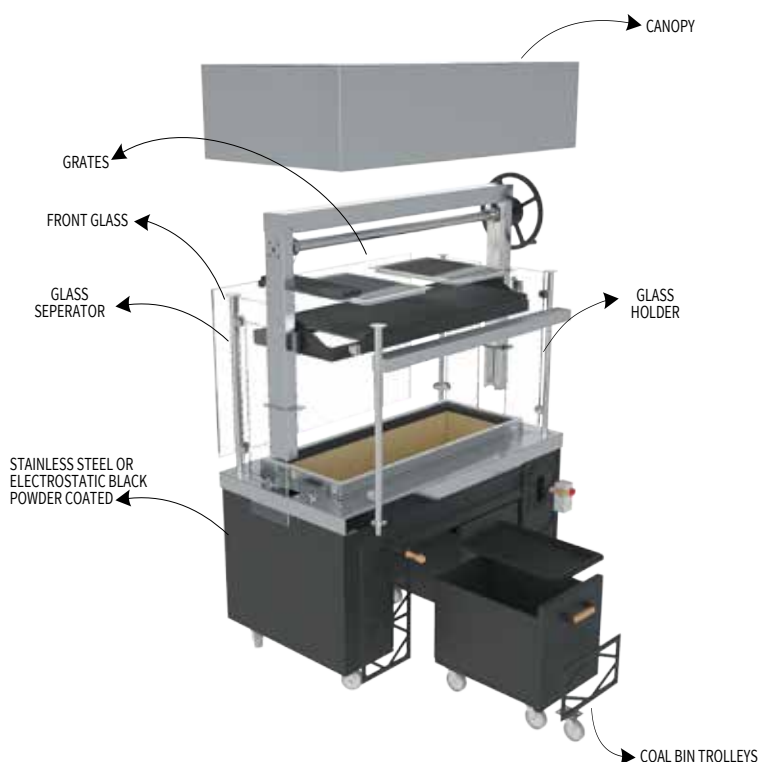

## GRATE OPTIONS

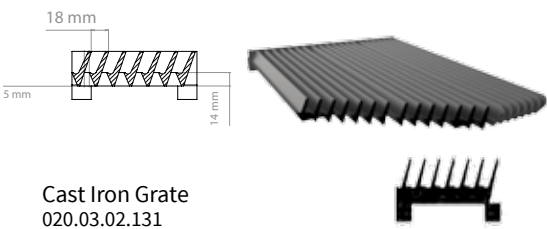
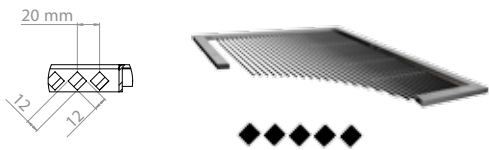
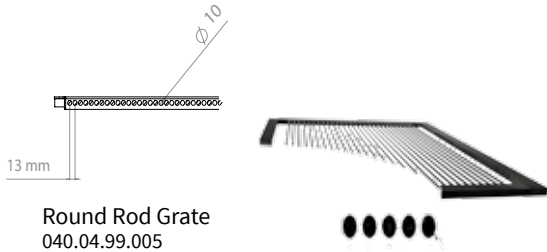





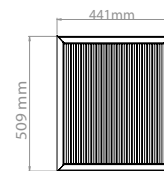



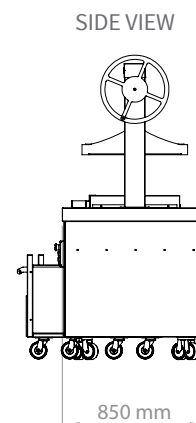
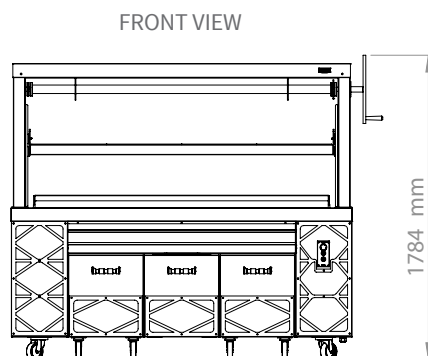
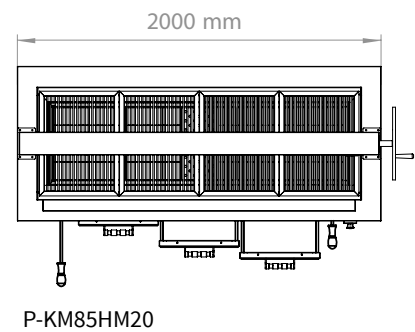
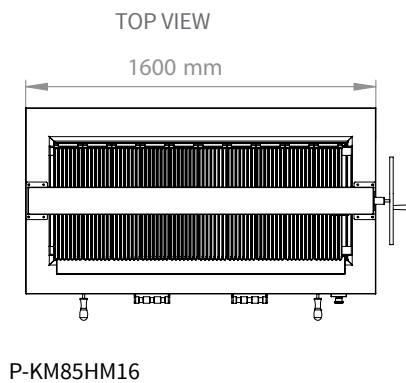
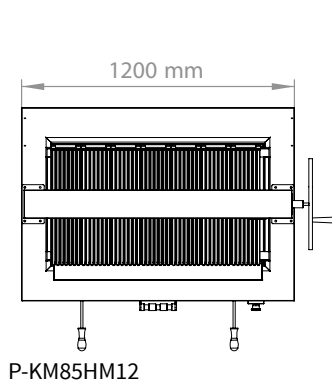
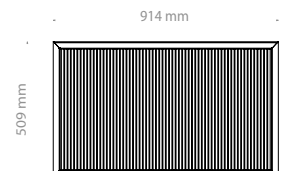







GRATE	CAST IRON GRATE	SQUARE ROD GRATE	ROUND ROD GRATE
Dimensions	130x515 mm	441x509 mm	441x509 mm
Rod Features	18 mm between grates	12x12 mm rod	ø10mm rod









One Module Cooking Surface Dimensions



Two Module Cooking Surface Dimensions



Code		Features	Code		Features
020.03.08.167		Extra Basket for Fryers Double 700- series GAS Dim 140x280x130	020.03.08.165		Extra Basket for Fryers Single 700- series GAS Dim 260x280x130
020.03.08.159		Extra Basket for Freyers Single 900- series GAS Dim 350x260x130	020.03.08.008		Extra Basket for Freyers Double 700- series ELECTRICAL Dim 140x280x170
020.03.08.005		Extra Basket for Freyers Double 900- series GAS Dim 350x140x130	020.03.08.166		Extra Basket for Pasta Cooker 900- series ELECTRICAL Dim 135x135x180
020.03.08.009		Extra Basket for Pasta Cooker 700-900- series ELECTRICAL Dim 270x145x180	020.03.08.156		Extra Basket for Pasta Cooker 700- series ELECTRICAL Dim 135x180x180
020.03.08.150		Extra Basket for Pasta Cooker 700-900- series ELECTRICAL Dim 130x180x255	020.03.08.157		Extra Basket for Pasta Cooker 700- 700 S- series ELECTRICAL Dim 270x145x150
020.03.161		Extra Basket for Pasta Cooker 900- series GAS Dim 115x190x255	020.03.08.169		Extra Basket for Pasta Cooker 600- series GAS Dim 160x100x135
020.03.08.162		Extra Basket for Pasta Cooker 900- series GAS Dim 115x160x255	020.03.08.170		Extra Basket for Freyes 600- series GAS Dim 195x290x90
020.03.08.168		Extra Basket for Fryers 600- series ELECTRICAL Dim 195x265x130			

Code		Features	Code		Features
7RC100G		Reduction	088.003.001		Scraper for Lavastone Griddle cleaning
9RC100G		Reduction	088.004.001		Scraper for Lavastone Griddle cleaning
040.04.02.150		Lavastone Charcoal	020.03.10.056		Extra enameled coated GN 2/1 x 65mm tray for all ranges
020.02.04.250		Extra grid for all ranges	020.03.10.052		Extra S/S GN 2/1 x 65 mm tray for all series
87GP0341		Fryer basket support			

## type of packaging





notes

**KUSINA<sup>®</sup>**

## **GÜRÇELİK**

Dayanikli Tuketim Mamulleri Mutfak Ins. Tur. Tar. San. Tic. Ltd. Sti.

### **Head Quarter**

Bahcelievler Mah. Sakarya Cad. No:8 Yazibasi Torbali / Izmir - Turkey

Tel: +90 232 853 92 00 / Fax: +90 232 853 91 99

gurcelik@gurcelik.com.tr / www.gurcelik.com.tr

**www.kusina.com.tr**

All Rights Reserved

Company keeps it's right reserved to change model and design