

# ***KUSINA***

---

---

**BOILING PAN (GAS)**

---

---

**INSTRUCTION AND  
MAINTENANCE MANUAL**

*“Professionally with Professionals”*

## DESCRIPTION

Our dear customer,

Your preferred KUSİNA is nature and technology friendly. We thank you for your choice.

KUSİNA has been produced with the understanding of "Total Quality" in modern production facilities.

### Important Safety Information

**Carefully read this guide and keep it for future review.**

**WARNING:** Installation of the devices must be done by an authorized service person.

**WARNING:** Equipment must be grounded.



Indicates that there is a risk of personal injury or property damage.



Explosion / fire hazard.

- The instructions in this manual contain important information on the safe mounting, usage, cleaning and maintenance of the device. Thus, keep the manual at a place easily accessible by the person who will use the machine, and the technician.
- Mounting, conversions for different gas groups or electrical inlet, and maintenance works of the device should be performed by a specialist authorized in this subject and in accordance with the instructions of the manufacturer company.
- Gas and electrical connections of the device should be arranged according to the tables and electrical diagram given in this manual.
- Manufacturer company accepts no responsibility for the final damages incurred in humans or properties that are caused by any procedure not conforming to the instruction manual, or maintenance or technical interventions that are not performed by authorized people.

## MOUNTING

### Placement

- In order to prevent smell and fume formation, place the device beneath an exhaust hood being capable of enough ventilation.
- Place the device at a place min. 10cm away from the side or back wall to prevent excessive temperature rises. Figure A
- Remove the nylon protection cover on the device. If there are any adhesive residues left on the surface, clean with a suitable solvent (for example, Henkel-Helios).
- Balance the device by adjusting its four adjustable legs on a suitable ground.
- Install discharge tap no "2" and water filling tap no "1" on their places (If it is not installed).

### Gas Connection

- Have the gas connection of the device carried out by an authorized service employee.
- Device should be connected in accordance with the national and local gas standards of the relevant country. Connection to the gas installation should be made with flex pipe and ball valve. Fix the said ball valve to a place that is away from heat and easily accessible in case of a danger
- In order to cut off the gas immediately in cases of emergency, gas valve must be mounted on an easily accessible place.
- Gas inlets of the device are indicated with a label on device body
- After all connections are completed, check for gas leakage at joints.
- Feed the device with the gas and pressure as specified on device information plate and adjusted. If the gas type to which the device was adjusted for is not suitable to the gas type at the mounted place, follow the instructions written below
- Check whether the device is suitable for connected gas type. If not, see "Conversion to Different Gas Types"

## Electrical Connection

- Connect the device to a proper network only according to the electrical installation standards of DIN VDE 0100.
- Device should be fed with network voltage of 220-230V 50-60Hz.
- Cable should be at least of H05 RNF quality and its section should be selected to be sufficient to carry the maximum current.
- Automated fuse should be placed between the device and the network.
- It is recommended to include a leakage current fuse in the feeding installation.
- Voltage tolerance should not exceed  $\pm 10\%$ .

The device must be grounded. Grounding point is marked with "  ".

## Water connection

- Connect to hot-cold water inlet through a pipe of suitable section. Water inlet should be between 1,5 – 2,5 bar.
- Mount a mechanical filter on the water inlet of the device and the dirt and metal particles that may intrude in the device will be prevented through that filter.
- Before connecting the last pipe part to the machine, clean the accumulated dirt by discharging some water and then complete the connection.

## CONVERSION TO DIFFERENT GAS TYPES

- If the device will be operated with a different gas, perform following procedures. Required nozzles and adhesive labels are provided in a bag with the device.

### Replacement of pilot and burner nozzles (Figure-D)

- Remove the device drain tap "2"
- Unscrew the fixing bolts of lower panel (6-7) Figure C
- Remove the lower panel "5" Figure C
- Replace the nozzle 9 from burner 8 with a suitable for the different gas Figure D
- Remove the pilot burner 10 and unscrew part 11 and replace the nozzle 12 with new one Figure D

## BEFORE USE

### Operational Check

- Operate the device according to usage instruction, and check burner ignition and flame suitability. Check for gas leakage and make sure that the funnel system functions properly.
- If needed, see "Possible Problems and Solutions" below.

### Thermal Power Check

- After mounting as well as conversion to different gas types or any maintenance operation, check the thermal power of the device.
- Thermal power of the device is given on table "T5".
- When nozzles replaced in the device with the aim of operating with different gas types, thermal power and inlet pressure of the device should be in accordance with table "T5". For inlet pressure check, see "Inlet pressure checks".

## **POSSIBLE PROBLEMS - CAUSES**

### **Pilot burner does not ignite or ignites with difficulty.**

- Gas inlet pressure is insufficient.
- Gas pipe or nozzle is blocked.
- Gas tap is faulty.
- Piezoelectric ignition system is faulty.
- Safety thermostat is faulty.

### **Main burner and Pilot burner go out during operation.**

- Thermocouple is faulty or there is incorrect connection.
- Gas tap is faulty.
- Safety thermostat is faulty or defective.

### **Main burner does not ignite or ignites with difficulty.**

- Gas pressure is insufficient.
- Nozzle is blocked.
- Gas tap is faulty.

### **Temperature control cannot be performed.**

- Gas tap is faulty.
- Thermostat is faulty.

## **REPLACEMENT OF SPARE PARTS**

**You must perform gas leakage check after each after each maintenance/repair work performed on the device.**

**Burner, pilot, thermocouple, gas tap, gas valve, spark plug, piezoelectric ignition button, thermostat**

- Remove the device control panel and lower panel.
- Replace the part with a new one by disassembling the connection parts.

**Safety thermostat**

- Remove the device control panel and lower panel.
- Replace the part with a new one by disassembling the connection parts.

**Water taps**

- Remove the device control panel and lower panel.
- Replace the part with a new one by disassembling the connection parts.

## WARNINGS

- **Pay attention not to contact hot surfaces of the device!**
- Thanks to the special oil whose boiling point is 320°C, there is no need for pressure safety plug, air discharge plug and water level control, which are used in watery systems, and therefore it provides ease of use.
- It saves energy as it conducts heat faster and maintains it longer than a watery system.
- Device is equipped with an indirect heating system; i.e. cooking tank is heated through the special oil burner which is present in the enclosed chamber (jacket) surrounding the tank and has high thermal conductivity, and the heated oil cooks the food.
- Device is designed for professional use and must be used only by person who are trained for this intention.
- Device is intended for cooking, do not use for another purpose.
- Before cooking, clean the interior part of the pan with hot water and detergent, and rinse it with plenty of water.
- **Never operate the device when there is not any water in the cooking tank (pan). Otherwise, stainless pan and other parts will be damaged due to excessive heating.**
- Have the mounting, gas connection and adjustments for different gas types of the device carried out by an authorized service employee.
- In case of any failure, close the gas inlet valve of the device..
- Commission only authorized services for maintenance and use genuine spare parts.
- Before starting to use the device, clean the surfaces especially those to be in contact with foods.

### Additional safety members

- If the oil temperature in the shell exceeds maximum control temperature, limit thermostat provides a safe use by cutting off the gas. In this case, close the gas inlet valve of the device and notify to the authorized service.
- Pan discharge valve has a structure that prevents unintended opening during the operation of the device (In order to open the discharge valve, rise up the valve control arm and push it clockwise).

## USAGE

### Filling Water to the Pan

- Make sure that the discharge tap no “8” below the front panel is closed.
- Turn on the water filling button no “9” (cold or hot) and fill the pan with water.

### Pan Control

- Oil temperature can be controlled between ~60÷180°C through thermostat (temperature control) button (No: 3).

**WARNING:** In order to obtain high efficiency from the device, when you filled the pan with water, firstly adjust the thermostat to the highest value (180°), and after the water boils, decrease it to desired value.

### **Ignition of Burners Figure B**

- Open the feeding valve on the gas network.
- Turn the gas control button “4” to position “Pilot burner ignition” 14 and push down. At the same time, press down the piezoelectric ignition button, as well. So, the spark needed for pilot burner flame is produced. Release gas control button approximately after 20 seconds. Pilot burner flame will continue to burn. If does not burn, repeat ignition process again. (Figure-2)
- Ignition can be checked through observation port.
- In order to ignite burners, turn the gas control button 4 to position “maximum flame”13
- Adjust temperature control button 3 to desired cooking temperature.
- In order to increase the temperature of 150Lt water in the pan from 20°C to 100°C, there is need for approximately 80 minutes with the top cover on closed position.

### **Turning off Burners**

- Turn temperature control button 3 to position "0".
- Turn gas control button 4 to position “off”.15
- Close the valve on the gas network.

### **Water Discharge**

- Rise up the arm of the discharge tap2 below the front panel and turn it clockwise. Figure B
- There should be an outlet through which the water drains under the discharge tap.

## **CLEANING and MAINTENANCE**

- **Do not wash the device with high pressurized water.**
- **You must switch off the gas and electrical connection of the device before starting to cleaning or maintenance activities.**
- Before it cools down completely, wipe the device with a cloth immersed in warm soapy water at the end of each working day.
- During cleaning the device surface, do not use corrosive material which may cause scratches on the surface such as detergents, wire brushes, etc.
- Clean the surfaces, which cannot be cleaned through abovementioned methods, with chemical solvents.
- If the device will not be used for a long period, coat the surfaces with a thin layer of Vaseline.
- In case of any extraordinary condition with the device, notify to the authorized service. Never allow unauthorized people to interfere in the device.

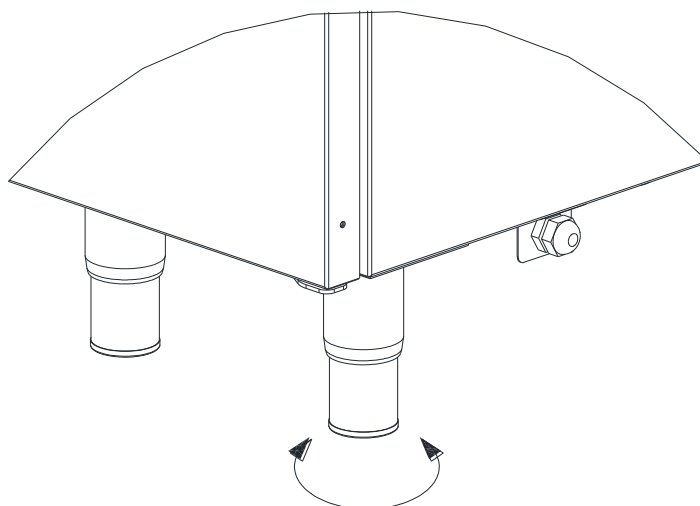

**Figure. A**

<b>MODEL</b>		<b>G9KT200G</b>	<b>G9KT201G</b>
WIDTH	mm	800	1200
DEPTH	mm	900	900
HEIGHT	mm	900	900
HEAT POWER	KW	21	31
PAN CAPACITY	Lt	150	250
GAS INLET	Inch	1/2"	1/2"
ELECTRICAL INLET	V	220-230V 50-60Hz	220-230V 50-60Hz
WATER INLET	Inch	1/2"	1/2"
GROSS WEIGHT	kg	180	275

### **Compatibility Information**

This device is designed and manufactured in accordance with the following directives and standards.



marking directive, 93/68/EEC

TS EN 203-1 / Gas Powered Cooking Appliances – Part 1:General Safety Appliances / 25.05.2015

TS EN 203-2-1 Gas Fired Catering Equipments - Part 2-1: Specifications – Open-tops / 02.04.2015

TS EN 203-2-2 Gas Burning Devices – Part 2-2: Special Rules – Ovens / 24.04.2008

- **Limitation of Liability:** All technical information contained in this manual, operating instructions, operation and maintenance of the device, contains the latest information on your device. The manufacturer accepts no responsibility for damage or injury which may result from failure to follow the instructions in this manual, use outside of the intended use, unauthorized repair, unauthorized modifications to the device, or use of spare parts not approved by the manufacturer.

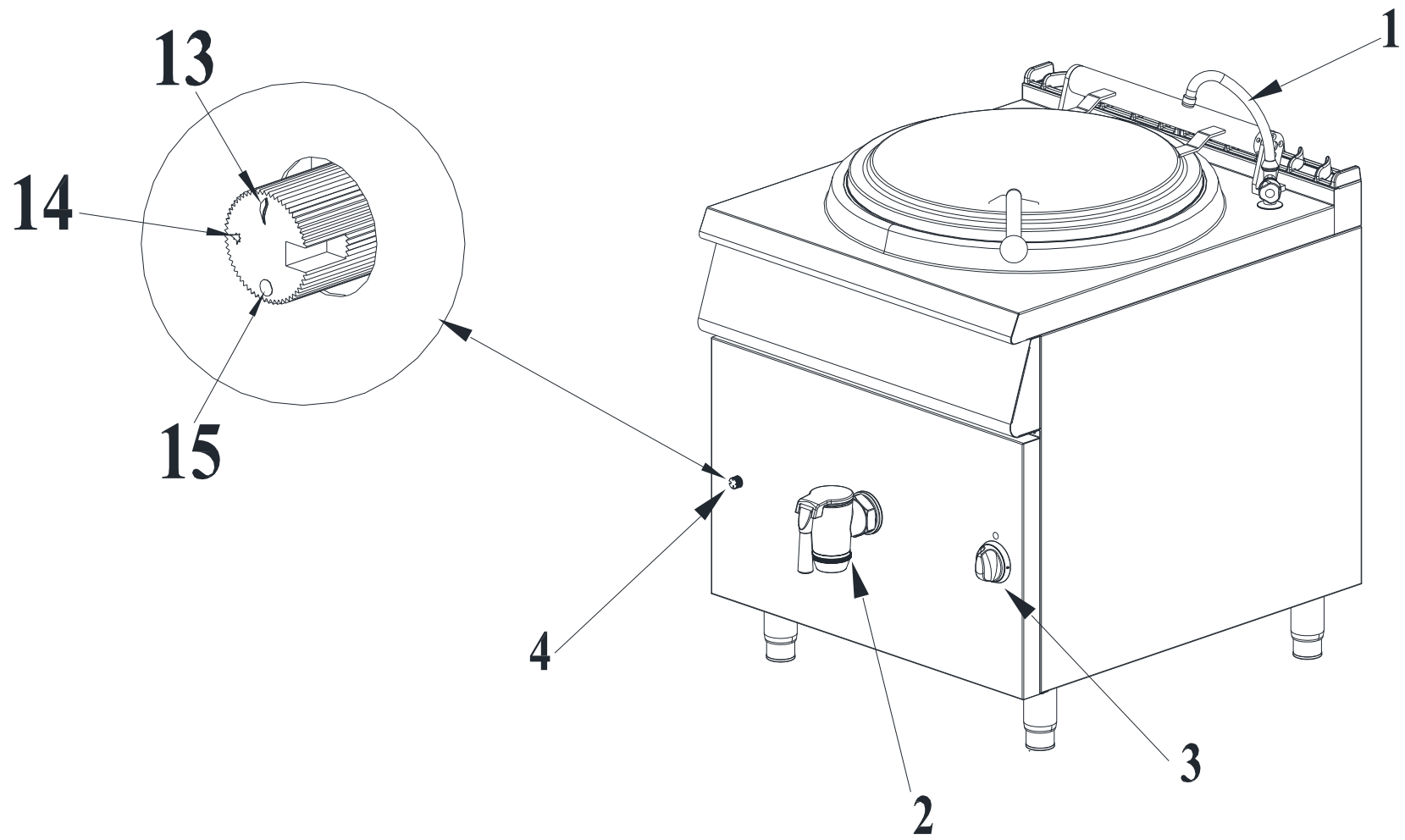

**Figure B**



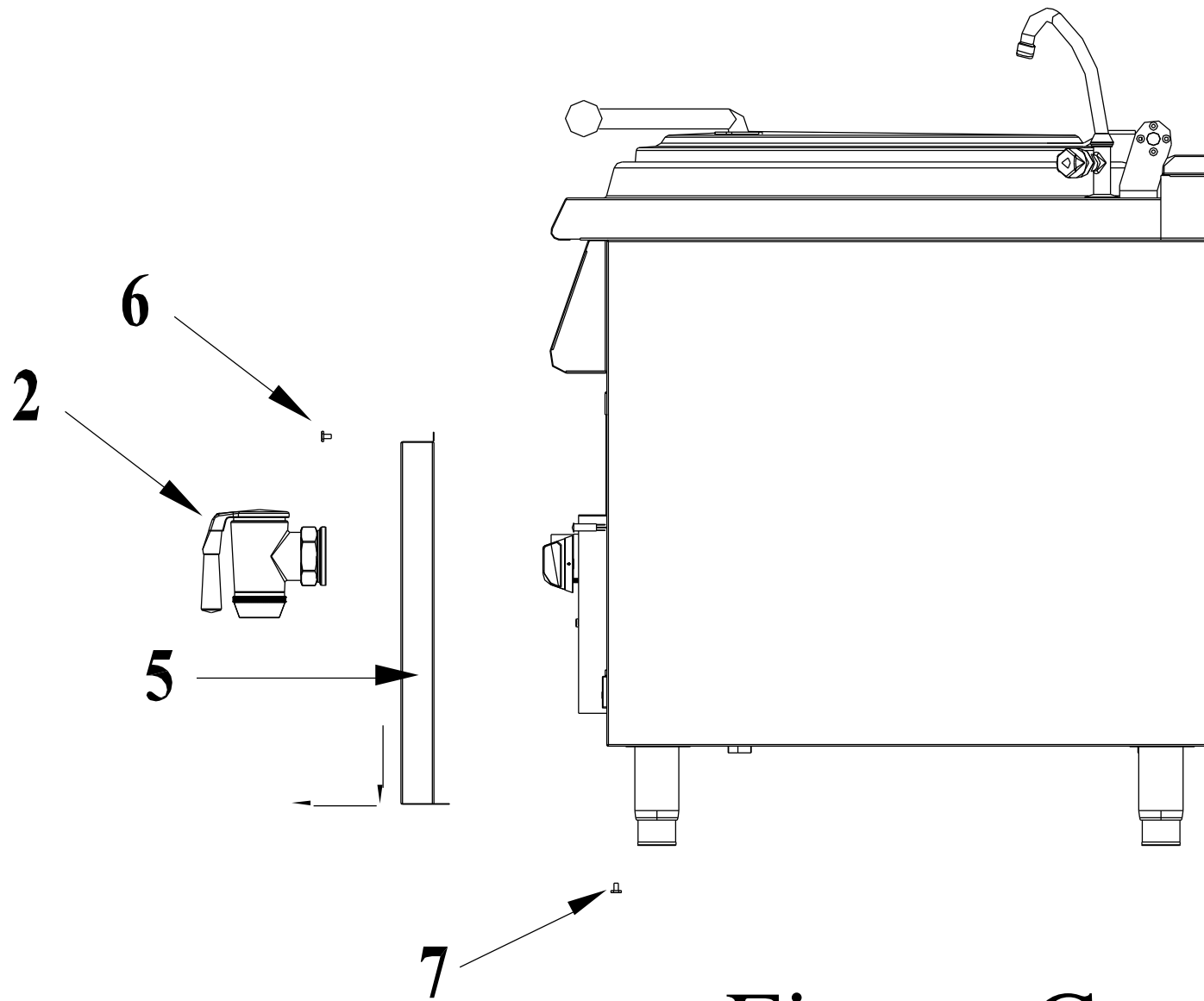

Figure C

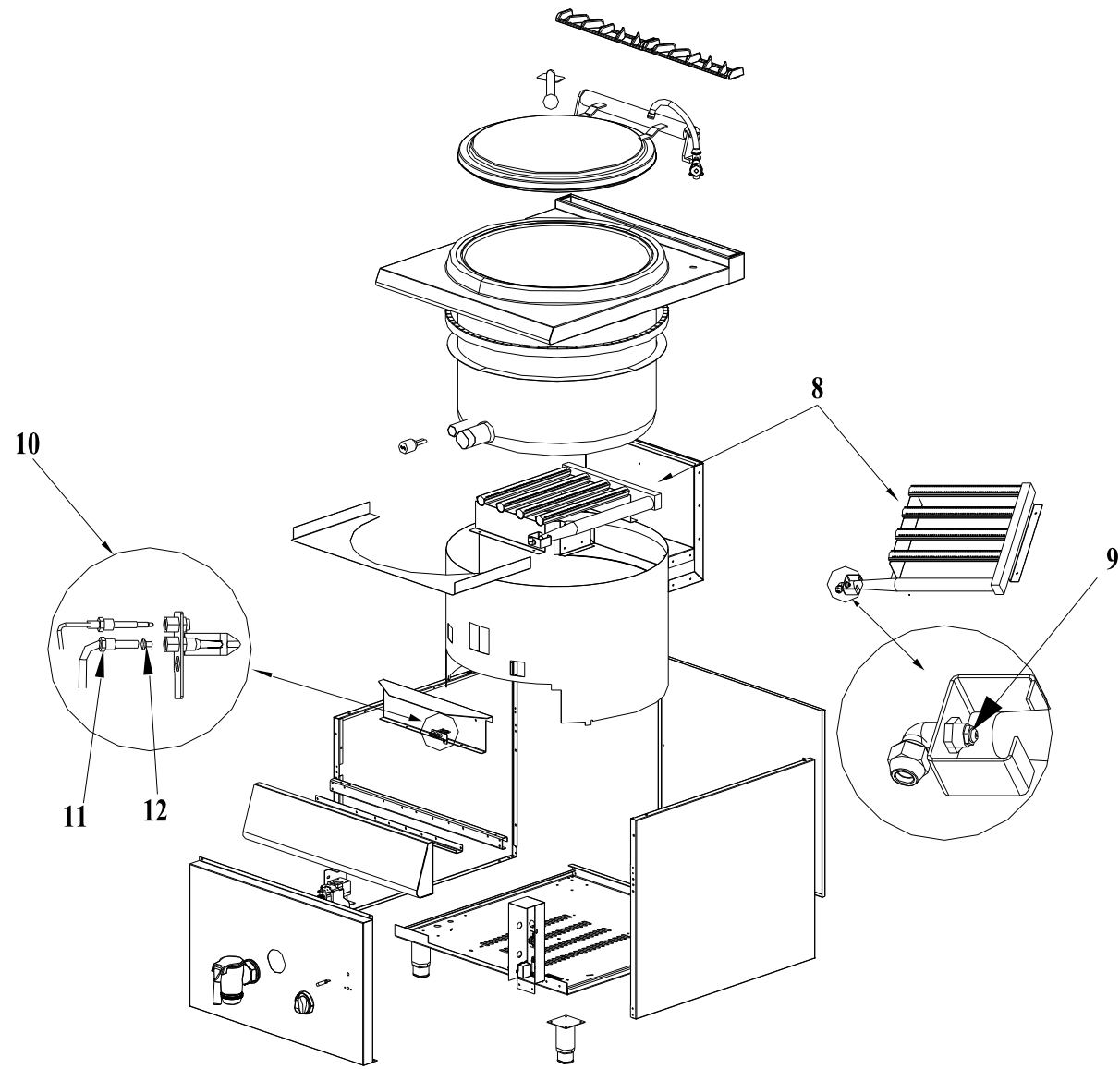
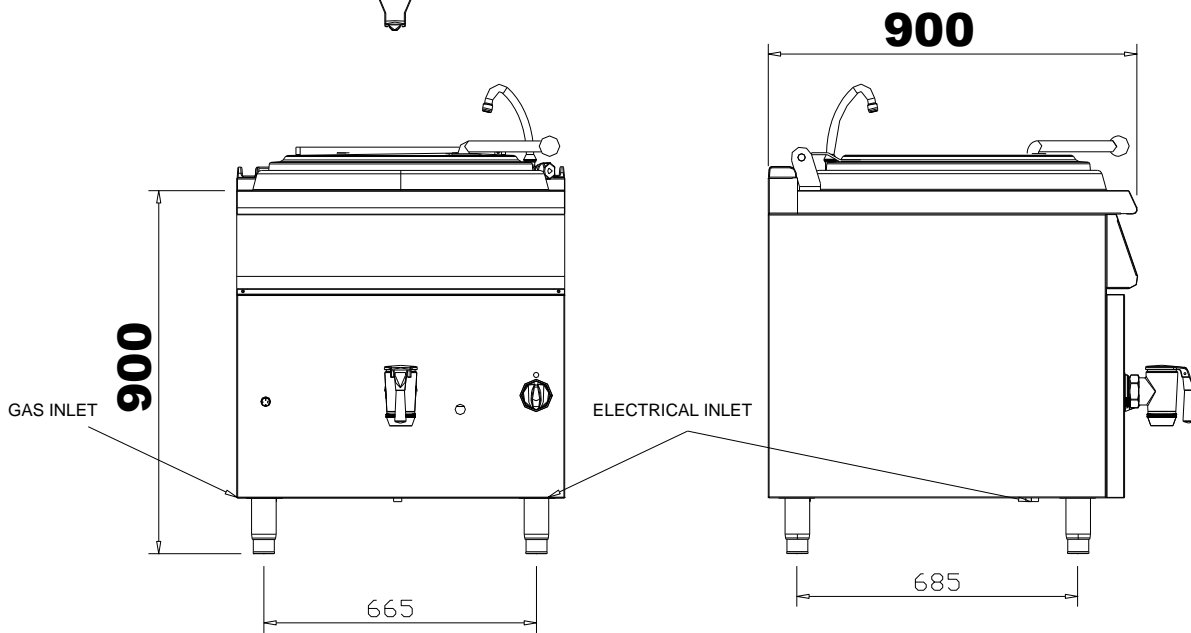
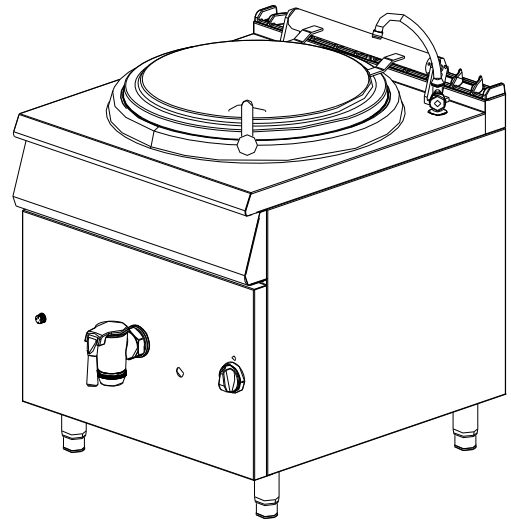
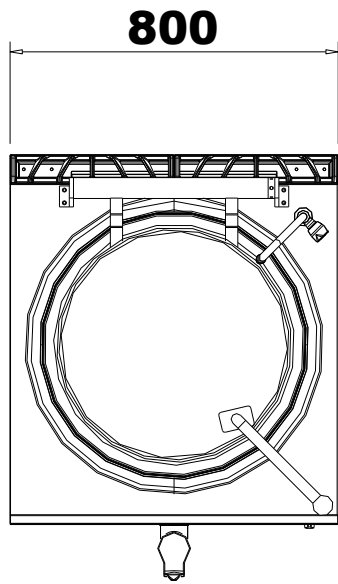
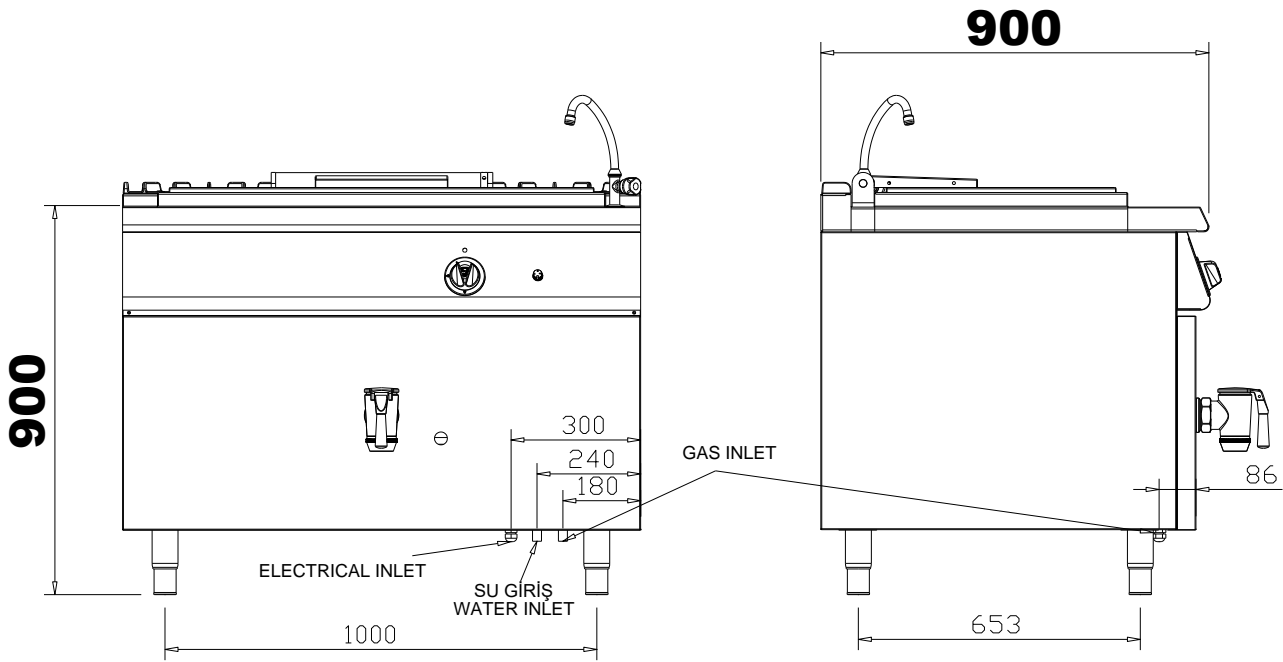
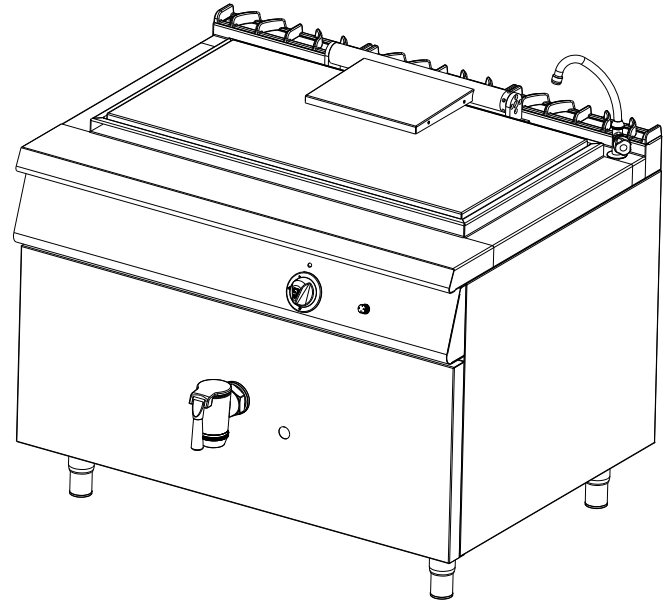
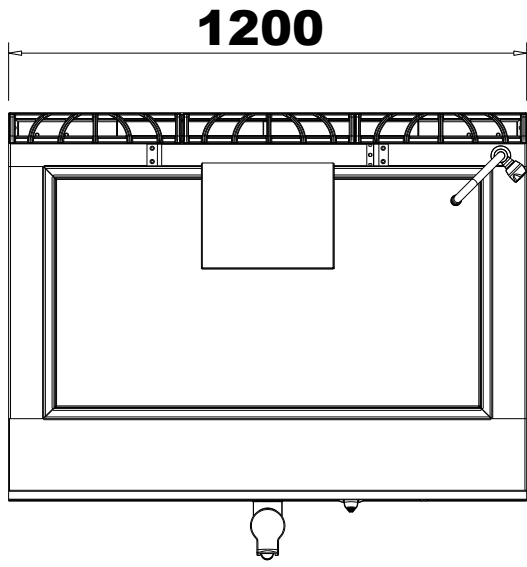

Figure D



**G9KT200G**



**G9KT201G**

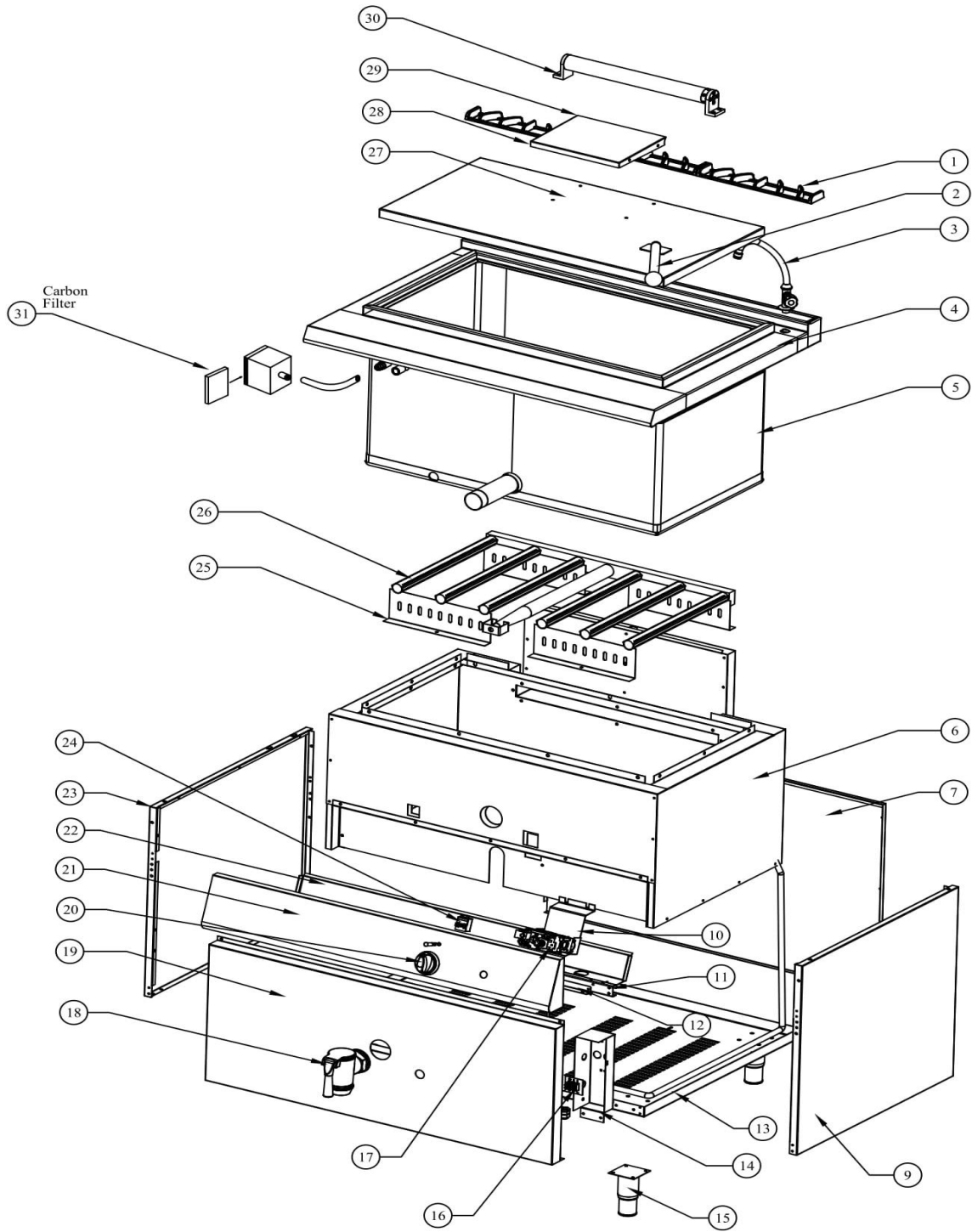

**Note: Please change the carbon filter every 6 months to prevent oil odor. The filter is under the front panel.**



# CORRECTIVE \ PREVENTIVE ACTIVE FORM

## DETECTION TYPE

OPTIMIZATION REQUEST/ DESCRIPTION	CUSTOMER NAME	CUSTOMER COMPLAINT	
PRODUCT NAME:		DETECTED ( Name , Appellation)	
DATE:		SIGN:	

## PROBLEM DESCRIPTION:

## SOLUTION PROPOSAL:

## EVALUATION:

## APPROVERS

--	--

Note: If required, you can send it to our company by viewing the form above or by post.

**+90 232 853 92 00**

**[www.kusina.com.tr](http://www.kusina.com.tr)**

**Info@kusina.com.tr**



As a KUSİNA, we realize the production of our devices with CE certificate.



We continue to contribute to the environment using recycled paper.

Manufacturer: Gürçelik Dayanıklı Tüketim Mamülleri Mut. Ins. Tur. Tar.San.Tic. Ltd.Sti.

Adress: Bahçelievler Mahallesi Sakarya Cad. No:11 Yazıbaşı/Torbalı- İZMİR

Phone: +90 232 853 92 00

Web: [www.kusina.com.tr](http://www.kusina.com.tr) – [www.gurcelikas.com](http://www.gurcelikas.com)

E-mail: [info@kusina.com.tr](mailto:info@kusina.com.tr)

**KUSİNA**

*is a*

**GÜRCELİK**  
PROFESSIONAL POWER OF PROJECT

*brand.*